

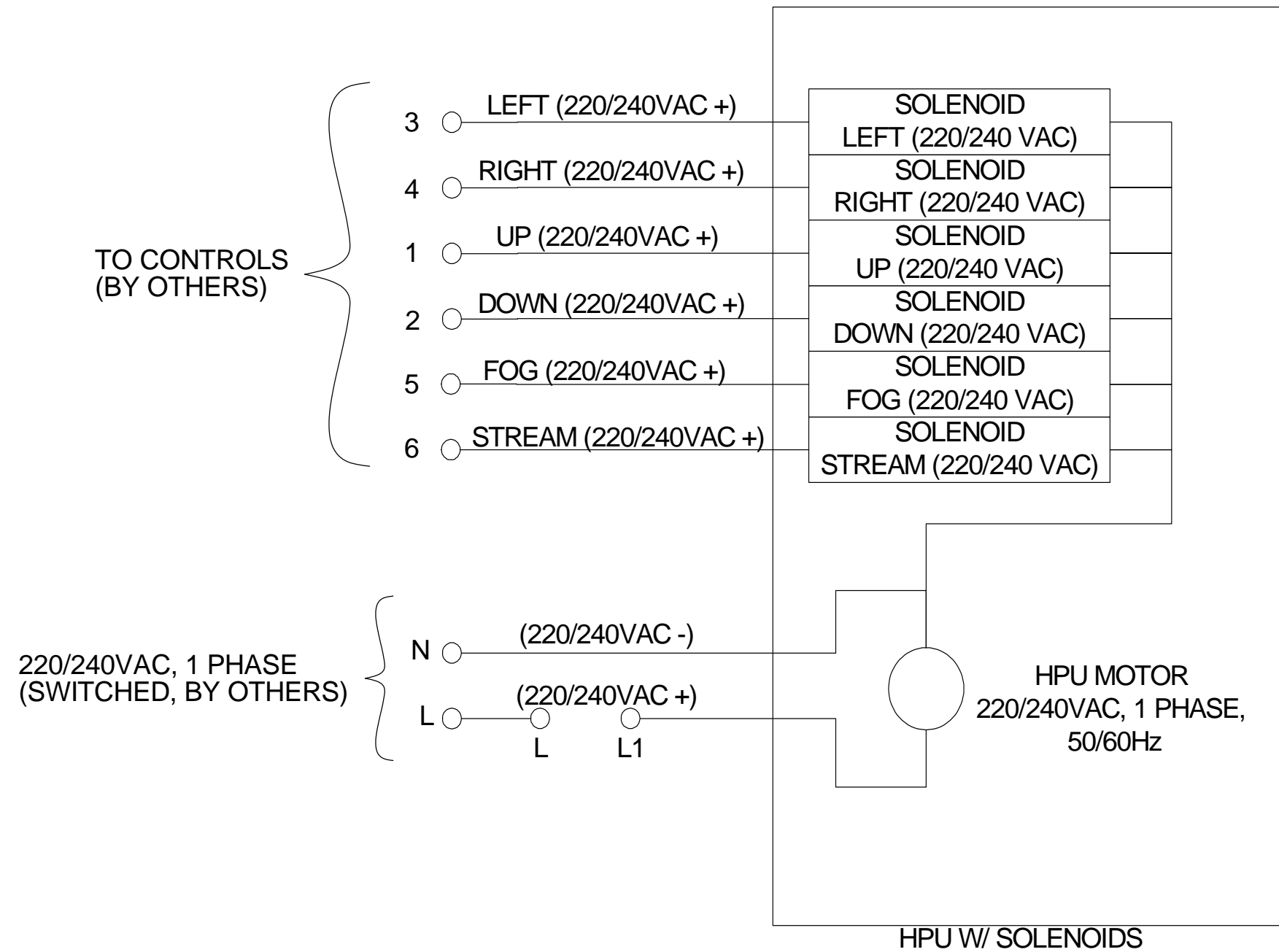

NOTES:
 1) DO NOT SCALE THIS DRAWING
 2) BREAK ALL SHARP EDGES

LTR	REVISIONS	DATE	BY
A	INITIAL RELEASE	08/31/05	RBS
B	ADDED TERMINAL DESIGNATIONS	09/13/05	RBS



UNLESS OTHERWISE SPECIFIED: DIMENSIONS ARE IN INCHES TOLERANCES DECIMALS ANGULAR .XX ±.03 ±1° .XXX ±.010 DO NOT SCALE DRAWING	 STANG INDUSTRIES, INC. 1250 RAILROAD ST. CORONA, CA 92882	
	WIRING DIAGRAM, HPU W/ SOLENOIDS	
TREATMENT -----	DRAWING NUMBER 105208-391	B
FINISH -----	CAGE 55822 DRAWN RBS	CHECK REVISION A
NOTE -----	DATE 08/31/05 DESIGN	SCALE 1:1 SHEET 1 OF 1

The information and design disclosed herein is the property of Stang Industries, Inc. All proprietary use and sales rights thereto are reserved. This disclosure is confidential and must not be copied in whole or part.