

LTR	REVISIONS	DATE	BY
A	INITIAL RELEASE	03/09/05	RBS
B	REMOVED TB-2 TO TB-3 CONNECTION, CONNECTED TB-3 TO TB-12	09/21/05	RBS

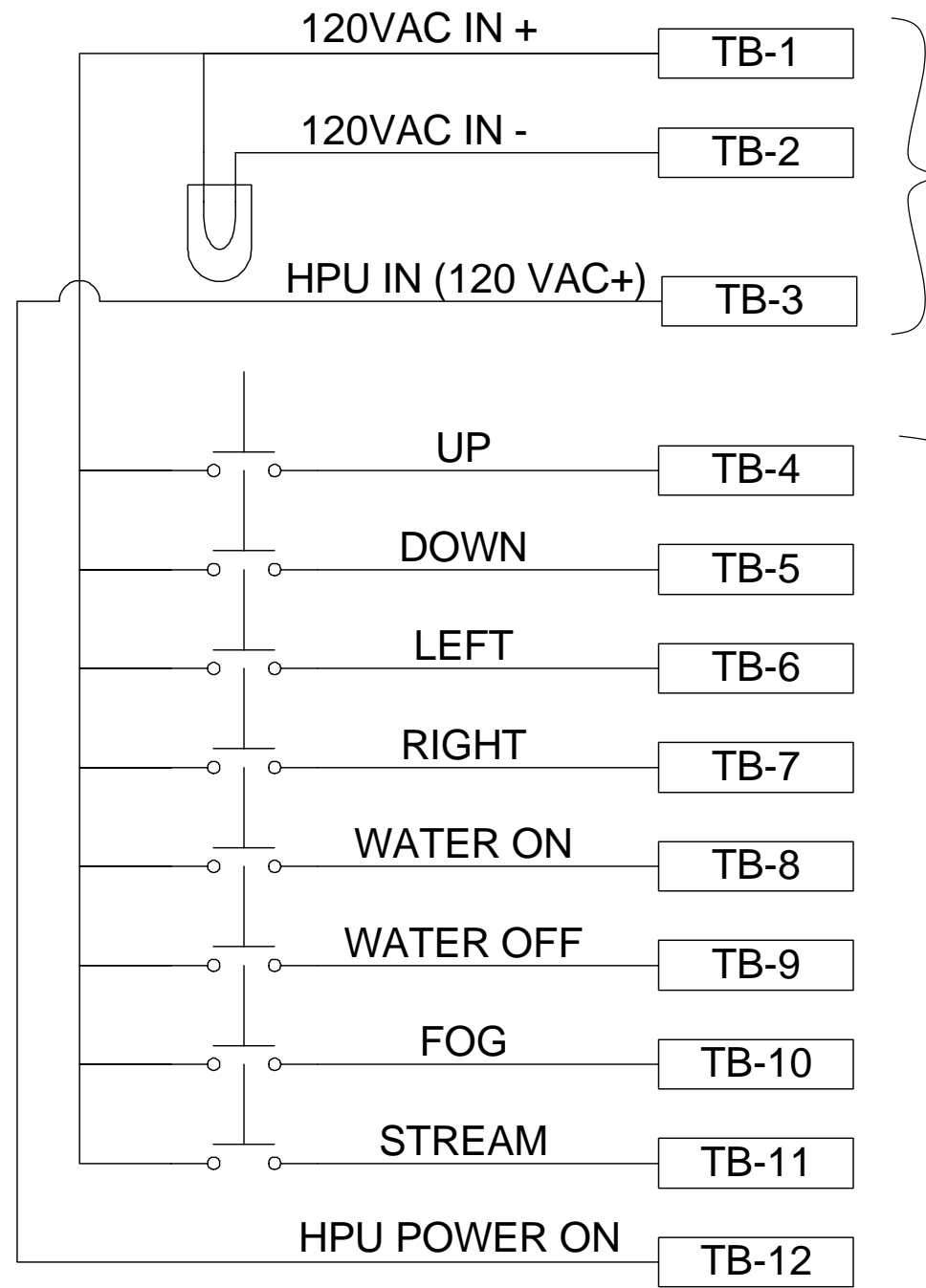

**120VAC INPUT POWER
(FROM MASTER PANEL)**

**OUTPUT TO CONTROL
VALVES**

NOTES:

1) DO NOT SCALE THIS DRAWING

2) ALL WIRING TO BE 14AWG MINIMUM

The information and design disclosed herein is the property of GST Industries Inc. All proprietary use and sales rights thereto are reserved. This disclosure is confidential and must not be copied in whole or part.

UNLESS OTHERWISE SPECIFIED: DIMENSIONS ARE IN INCHES TOLERANCES DECIMALS ANGULAR .XX ±.03 ±1° .XXX ±.010 DO NOT SCALE DRAWING		 STANG INDUSTRIAL PRODUCTS A DIVISION OF GST INDUSTRIES 16692 BURKE LN. HUNTINGTON BEACH, CA 92647	
		WIRING DIAGRAM, LOCAL CONTROL	
TREATMENT	-----	DRAWING NUMBER	105208-351
FINISH	-----	CAGE	55822
NOTE	-----	DRAWN	RBS
		DATE	03/09/05
		DESIGN	
		CHECK	
		REVISION	B
		SCALE	1:1
		SHEET	1 OF 1