

NOTES:

- 1) DO NOT SCALE THIS DRAWING
- 2) ALL WIRING BETWEEN HPU AND CONTROL PANEL TO BE (BY OTHERS)
- 3) PENETRATIONS INTO HPU J-BOX TO BE (BY OTHERS)
- 4) TERMINALS (TB-7) THROUGH (TB-12) ON CONTROL PANEL ARE SPARES
- 5) WIRE SIZE TO BE CHOSEN (BY OTHERS)

220/240VAC, 1 PHASE
(SWITCHED, BY OTHERS)

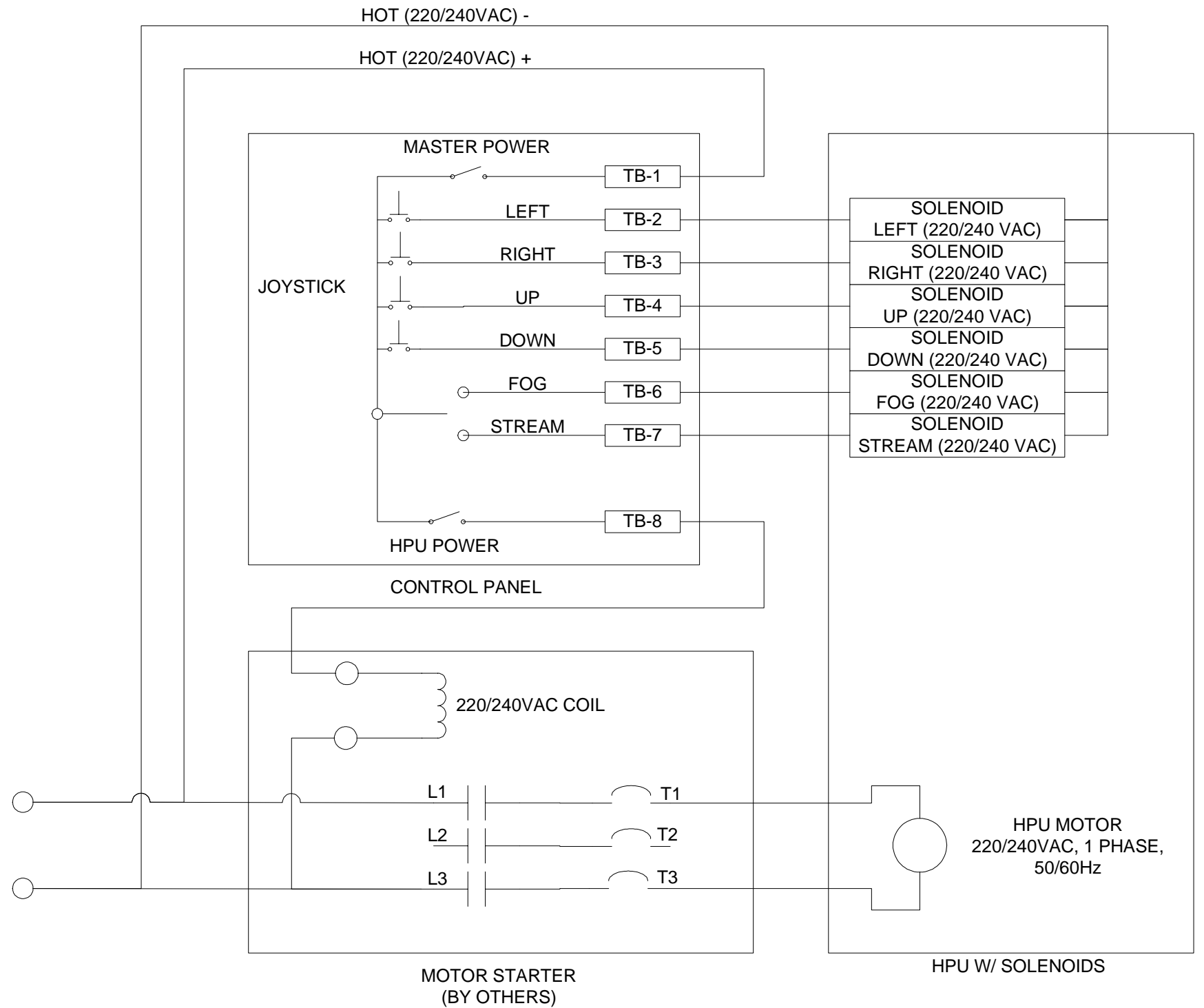

<p>UNLESS OTHERWISE SPECIFIED: DIMENSIONS ARE IN INCHES TOLERANCES DECIMALS ANGULAR .XX ±.03 ±2° .XXX ±.010 DO NOT SCALE DRAWING</p>		<p>STANG INDUSTRIAL PRODUCTS A DIVISION OF GST INDUSTRIES 16692 BURKE LN. HUNTINGTON BEACH, CA 92647</p>	
<p>SCHEMATIC, ELECTRICAL HPU & CONTROL VALVES</p>		<p>REF PART # B</p>	
<p>PART# 105208-211</p>		<p>REVISION</p>	
<p>TREATMENT</p>		<p>CAGE 55822 DRAWN RBS</p>	
<p>FINISH</p>		<p>CHECK</p>	
<p>NOTE</p>		<p>DATE 07/09/03 DESIGN SCALE 1:1 SHEET 1 OF 1</p>	

The information and design disclosed herein is the property of GST Industries Inc. All proprietary use and sales rights thereto are reserved. This disclosure is confidential and must not be copied in whole or part.

LTR	REVISIONS	DATE	BY