

Elevated Monitor System
Freestanding from 23' to 42' (7.0-12.8 Meters)
2.50", 3.00" & 4.00" Monitor Sizes
(60, 75 & 100mm)
Part # 103377

The Stang Elevated Monitor System has been the industry standard for well over 40 years. The 103377 series system is a freestanding (unsupported) water tower available from 23' to 42' (7.0-12.8 meters) in height. The monitor waterway sizes are 2.50", 3.00" or 4.00" (60, 75 or 100mm). The unit is manually controlled from ground level via a control handle which rotates a vertical & horizontal axis. The operator never has to leave ground level to operate, activate or do routine maintenance on this unit.

There are various options available for these systems which include shaper tip nozzles, hydraulic nozzles, manual fog/stream nozzles and remote swivel grease kits.

Features

- Aluminum Bronze Swivels
- Full 360° Horizontal Rotation & +45°/-45° Vertical Travel
- Horizontal Rotation & Vertical Travel Locks
- Electro-Galvanized Drivetube & Water Column
- Monitor Finish: Epoxy Coat
- Various Nozzle Options
- Remote Swivel Grease Kit

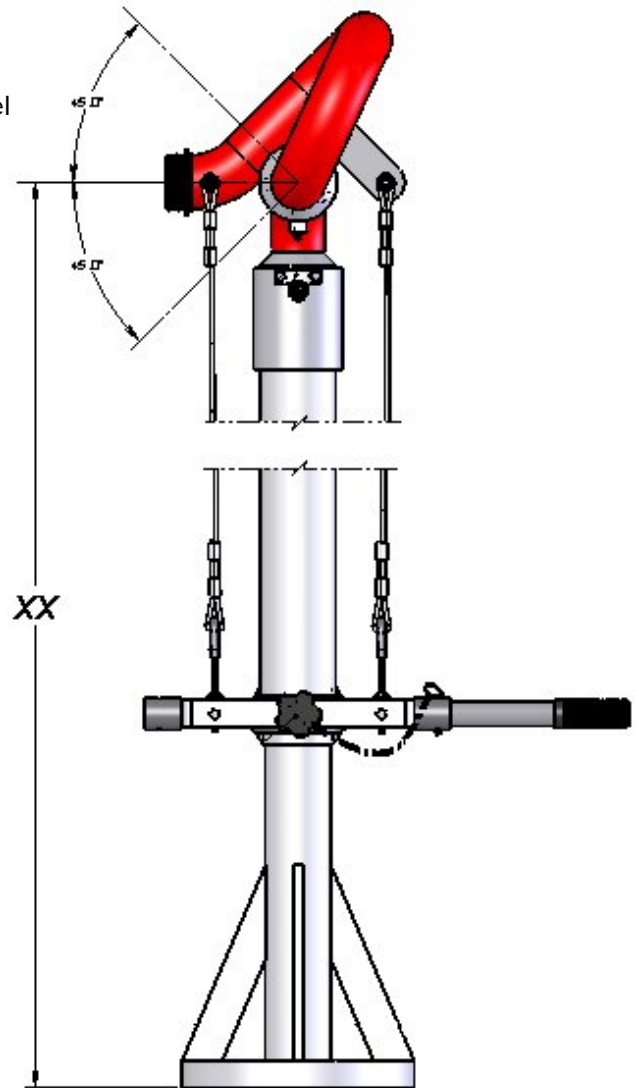
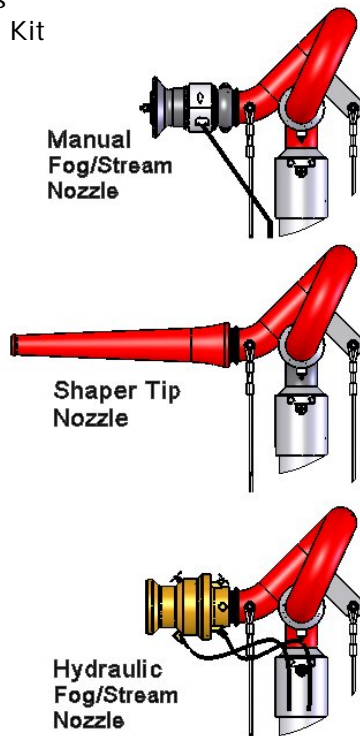

Please contact sales for more information.

*Part number does not include options or accessories.

DOC#: PB103377
 REV: A 01/05/07

Stang Industries
 951-479-9810
 www.stangindustries.com

Typical Installation

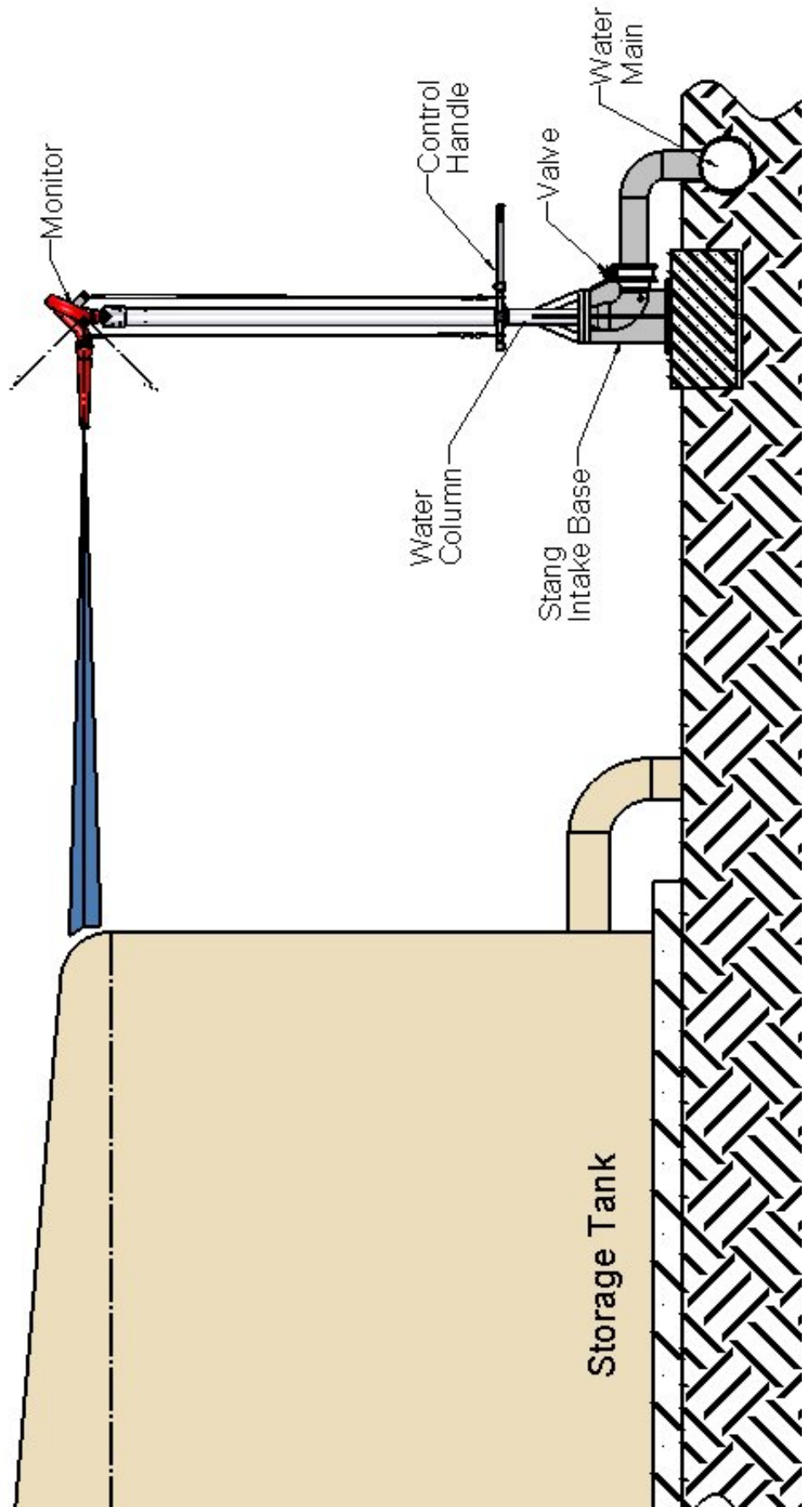

DOC#: PB103377
REV: A 01/05/07

Stang Industries
951-479-9810
www.stangindustries.com