

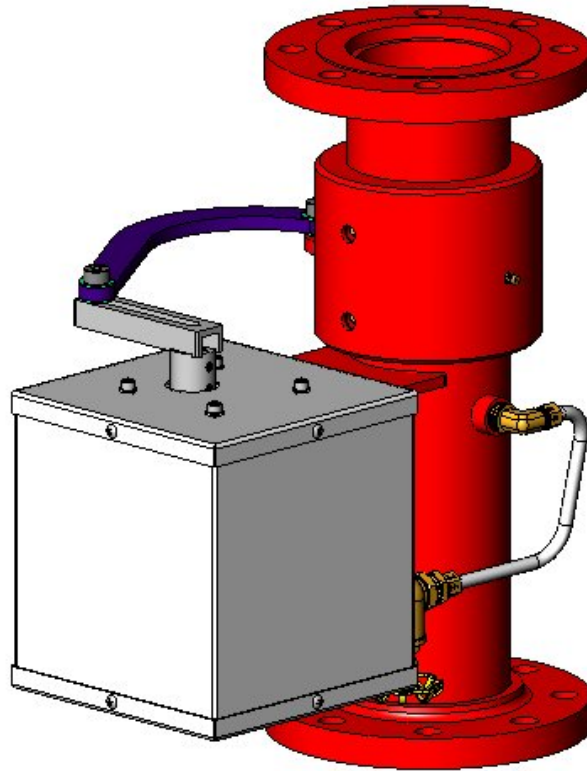

# Stang Industrial Products

## Operation and Maintenance Manual



**4.00" FLANGE TO FLANGE OSCILLATOR  
4.00-150#RF X 4.00-150#RF, STL-AB  
Model # 105425-91**

1250 Railroad St.  
Corona, Ca 92882 USA

[www.stangindustries.com](http://www.stangindustries.com)

09/2006

## 1. Introduction

The Stang 4.00" Oscillator is a water powered unit that has a 4.00"RF ANSI flange on the inlet and a 4.00"RF ANSI flange on the outlet. This product is used to oscillate the waterway axially. The oscillating motion is powered by a stream of water that shoots against a pelton wheel (enclosed in the sheet metal box). This stream of water is controlled via a gate valve.

## 2. Features & Specifications

- a. Flow:
  - i. Flow Rate: 1500-3000 USGPM
  - ii. Pressure Loss: 8PSI @ 2000 USGPM
- b. Pelton Wheel:
  - i. Flow Rate: 8 USGPM
  - ii. Speed: 1725 RPM
- c. Sweep:
  - i. Total Sweep Angle: 125° (adjustable)
- d. Speed:
  - i. Oscillation Speed: 5.5 cycles/min. (adjustable)
- e. Mounting:
  - i. Inlet/Outlet: 4.0" 150# RF Flange
- f. Materials:
  - i. Waterway: Coated Steel
  - ii. Flanges: Coated Steel
  - iii. Pelton Wheel: Brass
  - iv. Swivels: Aluminum Bronze
  - v. Cover Ass'y: 304 Stainless Steel
- g. Unit Weight: 76 lbs

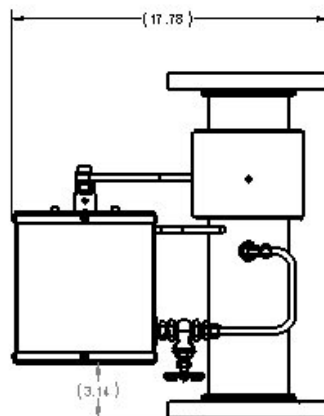
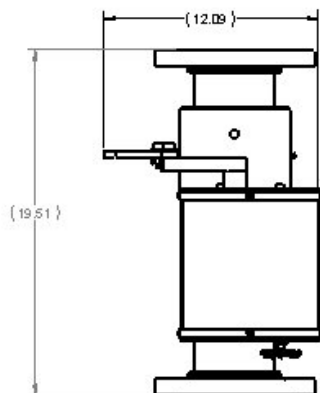
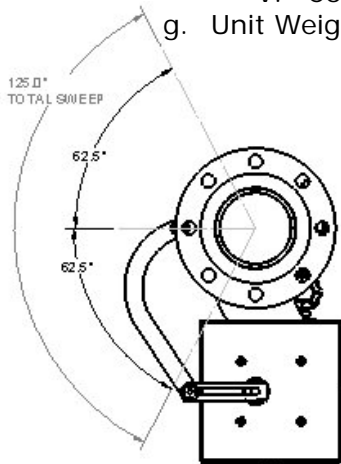
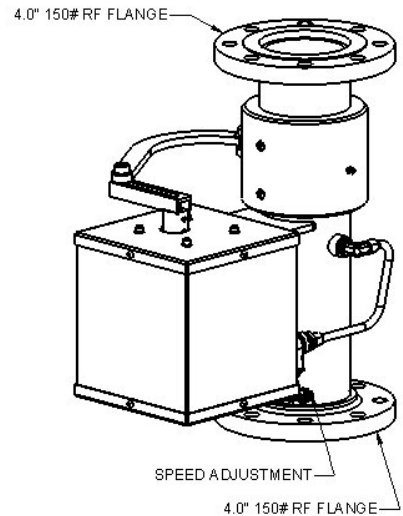

### 3. Installation

The Oscillator should be stood upright with the drive-arm upwards. The inlet end of the unit is the water source and the outlet end is the monitor (purchased separately). Attach to mating flanges with appropriate hardware (supplied by others) including ANSI flange gaskets. Tighten bolts & nuts to appropriate torque.

### 4. Operation

- a. Slowly turn on water.
- b. Open gate valve.
- c. Close gate valve to turn off motion.
- d. To adjust oscillating frequency & travel range, loosen bolt between item 6 & 16. The slot in item 6 allows for adjustment. Find the ideal operational parameters and re-tighten screw. (\*Make sure system is off)

### 5. Maintenance

- a. Keep swivel joints well greased as per swivel grease maintenance instructions.
- b. Make sure all moving parts are clean & operable and well lubed.

### 6. Exploded Parts Drawing

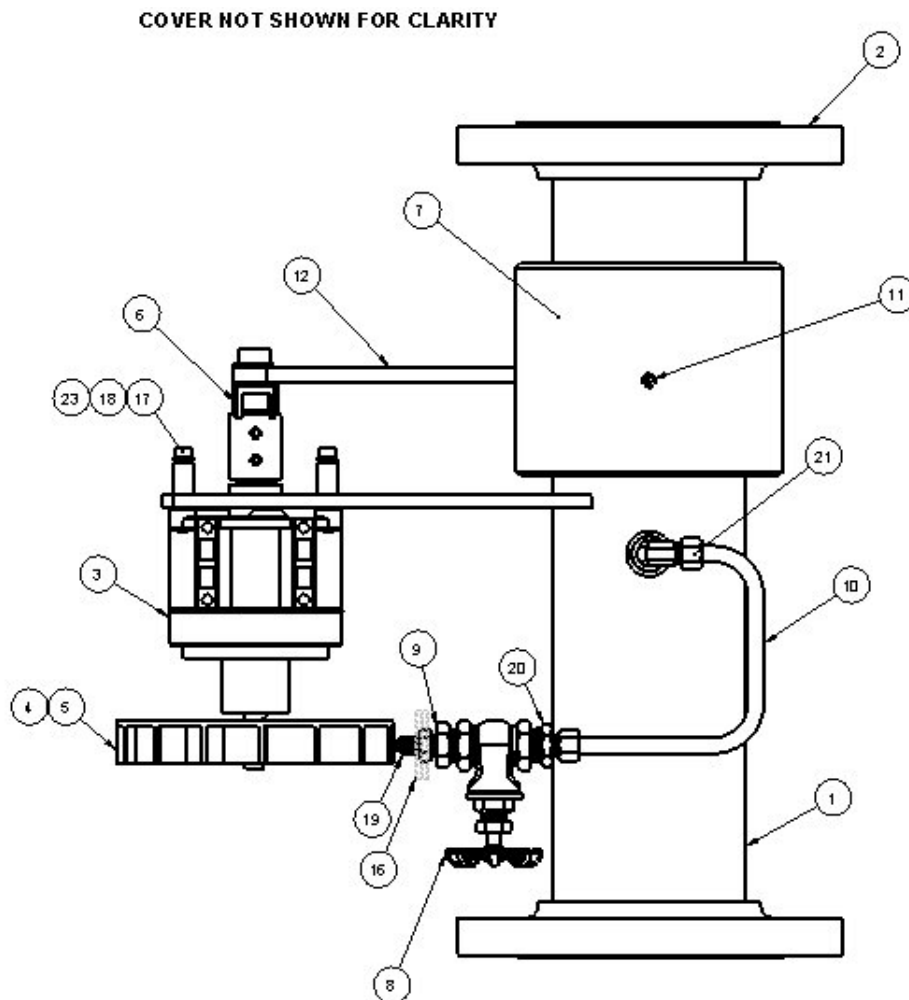

	23	111599-1	SPACER, .500OD X .250ID X .750L, ALUM	4
	22	112366-83238C	SCREW, TH, CROSS, 8-32UNC X .375L, 18-8	6
	21	121661-6-8-B	FITTING, 90°, 1/2NPT(M) X 3/8TUBE-BRS	1
	20	121656-6-8-B	FITTING, STR, 1/2NPT(M) X 3/8TUBE-BRS	1
	19	101816-2	FITTING, STR, 1/4NPT(M) X 7/16-20JIC(M)-BRASS	1
	18	103109-10C	WASHER, LOCK, SPLIT, 1/4" NOM, 18-8	4
	17	104033-175C	SCREW, SHC, 1/4-28UNF X 1.75L, 18-8	4
	16	101229-6	GROMMET, RUBBER, .75ID X 1.625OD X .313T-(GROOVE: .062T X 1.094OD)	1
NOT SHOWN	15	315009-12	SIDE, COVER ASS'Y, 304	1
NOT SHOWN	14	315009-11	LID, COVER ASS'Y, 304	2
NOT SHOWN	13	105542-1	U-NUT, 8-32UNC CRES	6
	12	105562-81	LINK ASSEMBLY	1
	11	100112-8	FITTING, ZERK, STR, 1/4-28UNF, CRES	1
	10	890900-1	TUBE, WATER DELIVERY	1
	9	102342-4B	FITTING, BUSHING, 1/2NPT(M) X 1/4NPT(F)-BRASS	1
	8	100239-1	GATE VALVE, 50 NPT (F)	1
NOT SHOWN	7	103831-1	SWIVEL KIT, 4.0 NOM.	1
	6	105502-1	DRIVE ARM ASSY, OSCILLATOR	1
	5	100067-8	SCREW, SET, CP, 1/4-20UNC X .38LG. 18-8	1
	4	105726-31	PELTON WHEEL, 6.50" DIA. BRASS	1
	3	105537-21L	SPEED REDUCER, (329:1 RATIO)	1
	2	105555-111	BASE, UPPER, 4.00RF OSCILLATOR-STL-AB	1
	1	105555-211	BASE LWR WELDMENT, 4.0" NOM., STL-AB	1
	ITEM #	PART #	DESCRIPTION	QTY

## 7. Swivel Joint Service Instructions

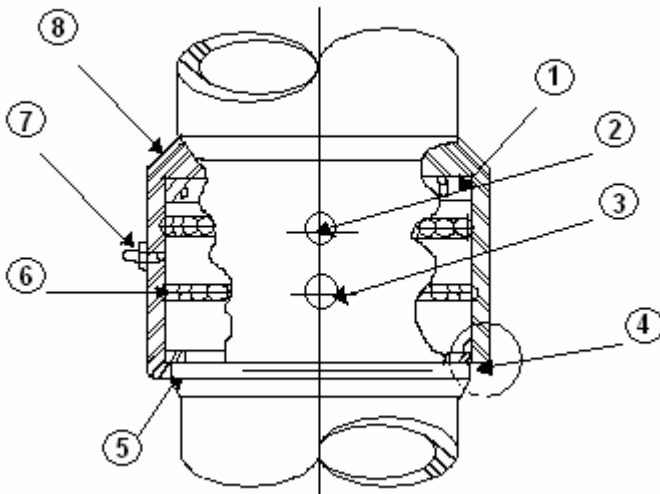

### Parts

1. Pressure Seal
2. Ball Retainer Plug
3. Retaining Ring (For Plug)
4. Dirt Seal
5. Inner Race
6. Steel Balls
7. Grease Zerk
8. Outer Race

### Equipment Needed

1. Retaining ring pliers (Truarc or equal: #1 internal rings on joints up to 4", and #3 for 6" joints and larger)
2. Sharp pointed tool (Example: alignment punch or ice pick).
3. Solvent to soften grease in ball races.
4. Cleaning material-rags.
5. Lubricant: All purpose grease, grade #2.
6. New Seals.

### Maintenance

1. Lubricate swivel joint through grease zerk (7) after each 24 hours of accumulated use.

**CAUTION: Excessive grease pressure can cause packing displacement and consequent leakage.**

2. Inspect swivel joint at regular intervals for water leakage. If leakage is detected, replace packing as described in the repair procedure.

### Repair

1. Disassembly:
  - A. With retaining ring pliers, remove the two retaining rings (3).
  - B. Insert sharp pointed tool into middle of the ball retainer plug (2) and lift at slight angle. The ball retainer plug has a metal plate on top with a small hole in the middle of the plate to aid in removal.
  - C. Rotate swivel joint to allow balls (6) to roll out of races. If grease is thick and heavy, balls may not fall free. Use solvent to clean. Balls will always roll out if races are clean. Parts will disassemble when all the balls have been removed, and the seals will be exposed. A flexible polyethylene rod or similar tool may be used to push balls from race.
2. Cleaning:
  - A. Remove old seals (1 & 4) and replace with new parts.
  - B. Thoroughly clean all parts and apply a thin coat of lubricant around the packing.

### Reassembly

1. Replace pressure seal with new part if necessary. Lips must face away from ball grooves. Put small amount of grease on seal to ease reassembly.
2. Replace dirt seal. (Item 4)
3. Press the separate swivel joint races together and drop in the balls until the races are filled.
4. Replace the ball retainer plugs (2).
5. Replace retainer rings (3) with retaining ring pliers.
6. Lubricate the ball race area by using a small hand grease gun to force a small amount of the lubricant through grease zerk (7). Then rotate one portion of the 90% and regrease. Repeat 2 more times.

**CAUTION: Do not over grease. Excessive grease pressure can cause leakage and/or difficult rotation.**