

STANG HYDRANT DATA SHEET

FILL IN DIMENSIONAL INFORMATION AS APPLICABLE

FOR USE WITH:

STANG MODEL: 103785-1-SO# BRACKET TYPE HYDRANT MOUNT MONITOR

STANG MODEL: 103787-1-SO# BRACKET TYPE HYDRANT MOUNT MONITOR (FLANGED)

STANG MODEL: 103785-11-SO# BRACKET TYPE HYDRANT MOUNT MONITOR

CUSTOMER MUST FILL OUT THIS SHEET AND SUBMIT TO STANG AT TIME OF ORDER. HYDRANT WILL BE FABRICATED TO DIMENSIONS PROVIDED. CONTACT STANG SALES FOR SPECIAL OPTIONS.

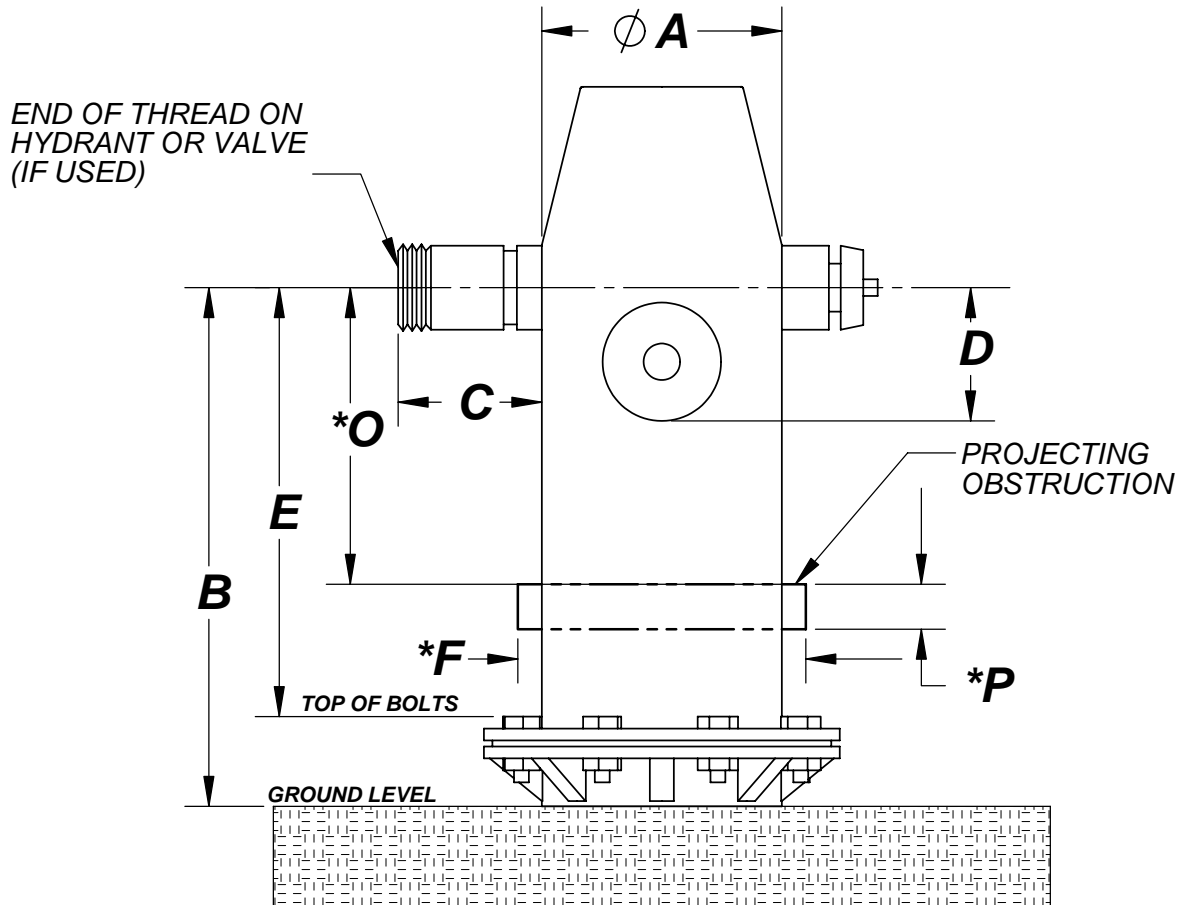

*NOTES:

GIVE "F", "O", & "P" DIMENSIONS OF ANY OBSTRUCTION ABOVE GROUND FLANGE. "O" MUST BE 10" MINIMUM WITHOUT VALVE ON OUTLET AND 12" MINIMUM WITH VALVE ON OUTLET.

A-		E-	
B-		*F-	
C-		*O-	
D-		*P-	
HYDRANT MAKE & MODEL #			
THREAD SIZE & TYPE			

CUSTOMER COMMENTS:

CUSTOMER SIGN OFF: _____



STANG INDUSTRIAL PRODUCTS
16692 BURKE LANE
HUNTINGTON BEACH, CA 92647
PH 714-556-0222 FX 714-546-8017
WWW.STANGINDUSTRIAL.COM

STANG USE ONLY

SO #: _____

CUSTOMER: _____