

NOTES:

1. DO NOT SCALE THIS DRAWING.
2. BREAK ALL SHARP EDGES.
3. ALL DIMENSIONS DISPLAYED IN PARENTHESES ARE FOR REFERENCE ONLY.
- 4) WHEN USING A DASH NUMBER WITH A DASH # SUFFIX, MAKE SURE THE DASH NUMBER SUFFIX IS THE SAME FOR THE MAJOR COMPONENTS IN THE ASSY. DO NOT ASSUME THE ACTUAL DASH NUMBERS ARE THE SAME.
EXAMPLE: A 940210-1EP USES THE FOLLOWING MAJOR COMPONENTS:
802110-1EP
802160-21EP
802220-21EP

PERFORMANCE SPECIFICATIONS	
WATER:	
FLOW RATE: 1500-3000 USGPM	
OPER. PRESSURE RANGE: 50-150 PSIG	
PRESSURE LOSS @ 2000 USGPM: 17 PSIG	
OPTIMUM OPER. PRESSURE: 120PSIG (INLET)	
MATERIALS:	
WATERWAY: 304 STAINLESS STEEL	
SWIVELS: 304 STAINLESS STEEL	
THREAD BUTT: 304 STAINLESS STEEL	
UNIT WEIGHT: 95 LBS ± DEPENDING ON BASE (DRY)	

REVISIONS			
REV.	DESCRIPTION	DATE	BY
A	INITIAL RELEASE	03/01/05	EK

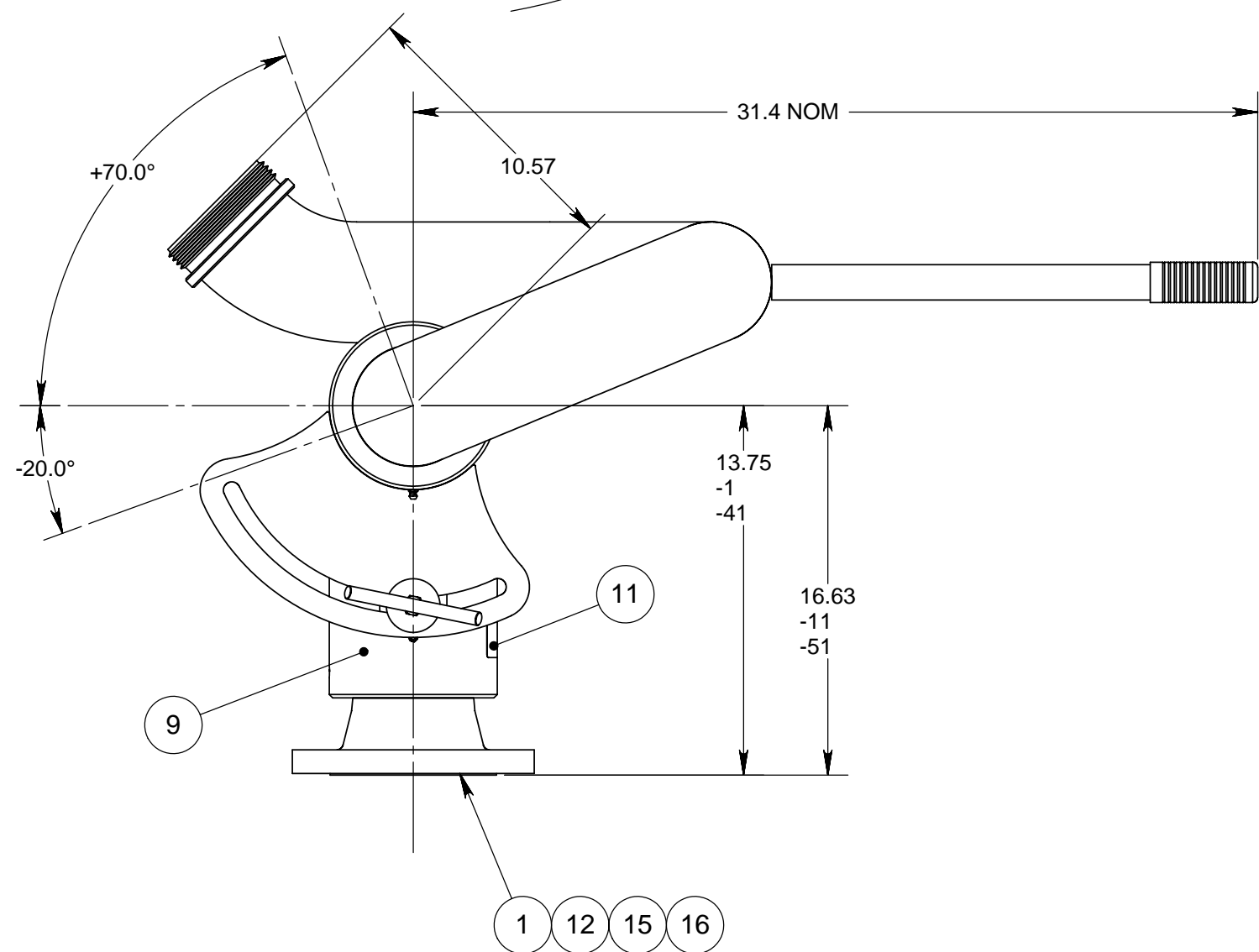
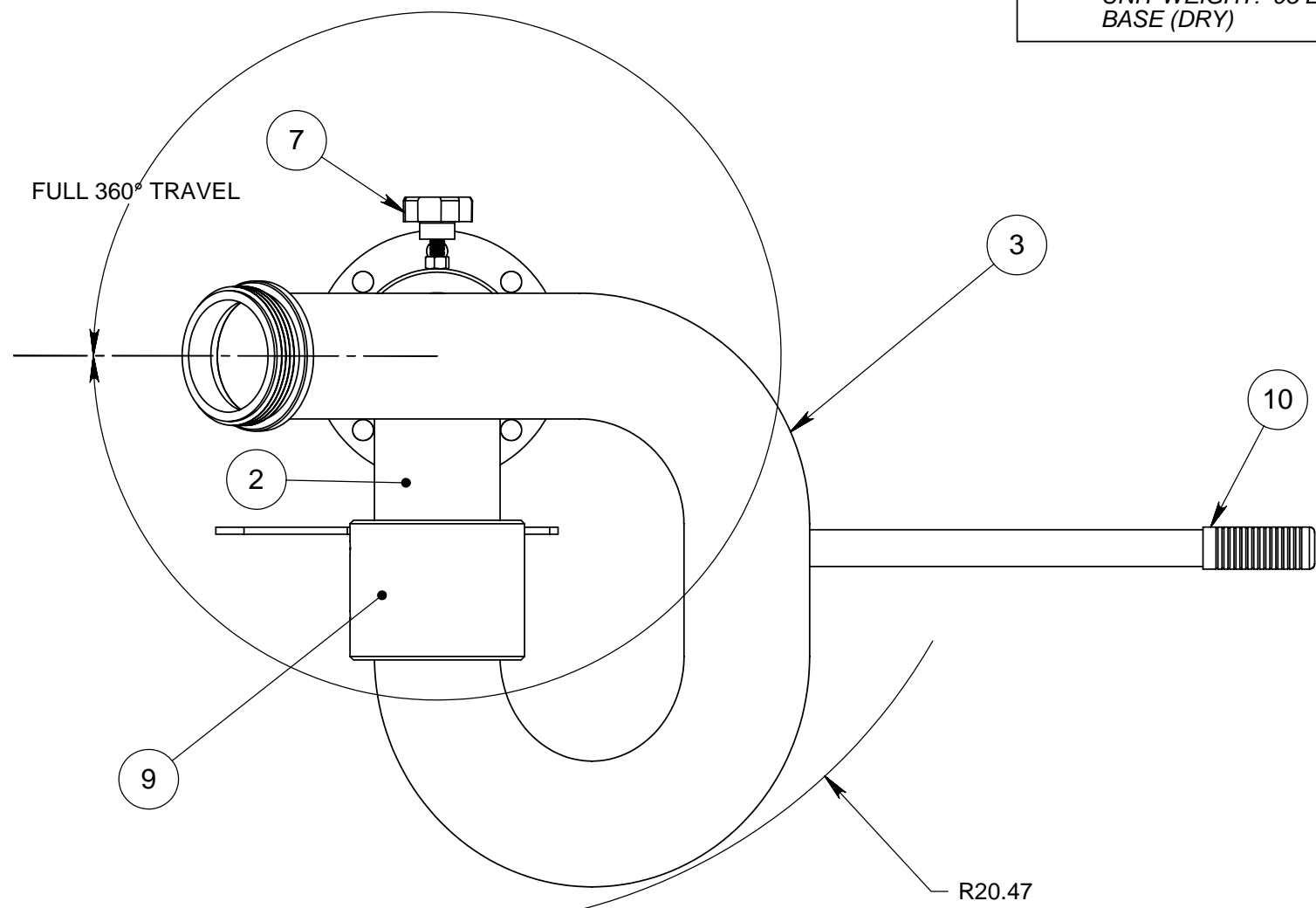

940210-1, -11, -41, -51

940210-21

DETAIL A
SAME FOR ALL
DASH NUMBERS

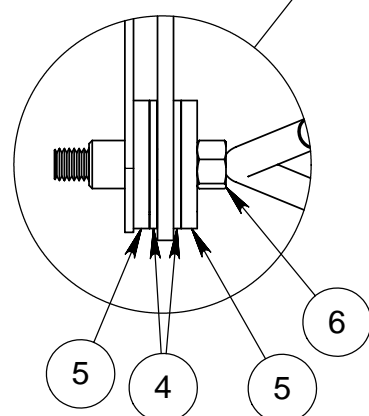

940210-31

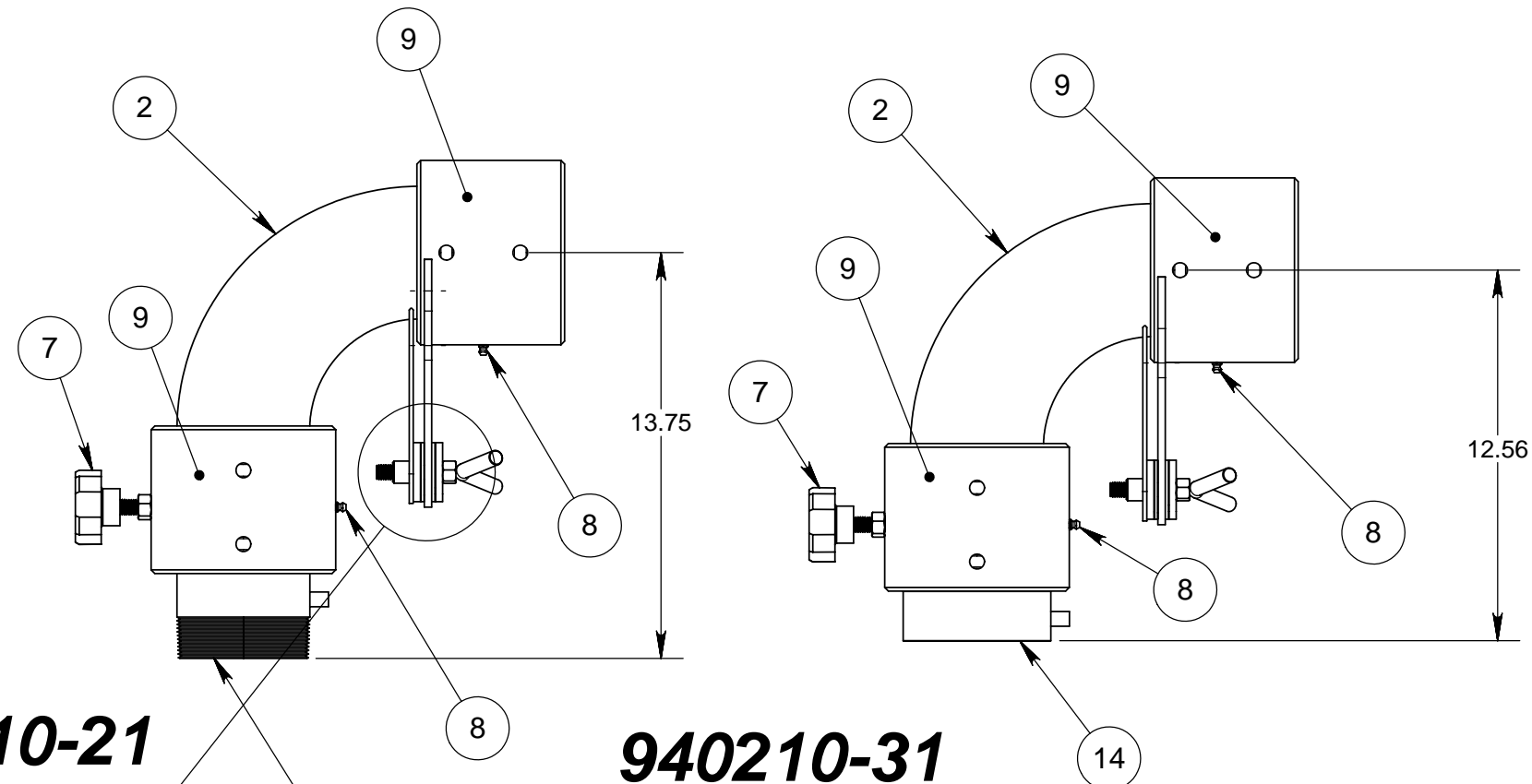

SUFFIX TABLE	
DASH #	DESCRIPTION
NO SUFFIX	POWDER COAT STANG RED
EP	EPOXY COAT STANG RED
P	POLISHED (SS ONLY)
NP	NOT PAINTED

CONFIGURATION TABLE	
940210-1	MONITOR, 4.00" STATION W/4.0-150#RF & BLADELOCK, SS
940210-11	MONITOR, 4.00" STATION W/6.0-150#RF & BLADELOCK, SS
940210-21	MONITOR, 4.00" STATION W/4.0NPT(M) & BLADELOCK, SS
940210-31	MONITOR, 4.00" STATION W/4.0NPT(F) & BLADELOCK, SS
940210-41	MONITOR, 4.00" STATION W/4.0-150#FF & BLADELOCK, SS
940210-51	MONITOR, 4.00" STATION W/6.0-150#FF & BLADELOCK, SS

1	-	-	-	-	-	16	802110-51	BASE INTAKE, 4.00" W/6.0-150#FF, SS
-	1	-	-	-	-	15	802110-41	BASE INTAKE, 4.00" W/4.0-150#FF, SS
-	-	1	-	-	-	14	802110-31	BASE INTAKE, 4.00" W/4.0NPT(F), SS
-	-	-	1	-	-	13	802110-21	BASE INTAKE, 4.00" W/4.0NPT(M), SS
-	-	-	-	1	-	12	802110-11	BASE INTAKE, 4.00" W/6.0-150#RF, SS
1	1	1	1	1	1	11	100853-1	PLATE, ALUM ID
1	1	1	1	1	1	10	100256-8	GRIP,HAND,BLK PLSTC,#RG28055
2	2	2	2	2	2	9	103831-1	SWIVEL KIT, 4.0 NOM.
2	2	2	2	2	2	8	100112-8	FITTING, ZERK, STR, 1/4-28UNF, CRES
1	1	1	1	1	1	7	102537-1	LOCK KNOB, 50-20UNF-2A THD
1	1	1	1	1	1	6	103815-11	LOCK HANDLE WELDMENT
2	2	2	2	2	2	5	103817-11-12	WASHER, FLAT, 2.00OD X .56ID X .25T, 304
2	2	2	2	2	2	4	105448-11	WASHER, FLAT, .50ID X 2.00OD X .120T, DELRIN
1	1	1	1	1	1	3	802220-21	ELL, UPPER, 4.00" STATION W/BLADELOCK, SS
1	1	1	1	1	1	2	802160-21	ELL, LOWER, 4.00" LR W/BLADELOCK, SS
-	-	-	-	-	1	1	802110-1	BASE INTAKE, 4.00" W/4.0-150#RF, SS
-51/QTY.	-41/QTY.	-31/QTY.	-21/QTY.	-11/QTY.	-1/QTY.	ITEM #	PART #	DESCRIPTION

UNLESS OTHERWISE SPECIFIED: DIMENSIONS ARE IN INCHES TOLERANCES DECIMALS ANGULAR .XX ±.03 ±1° .XXX ±.010 DO NOT SCALE DRAWING

TREATMENT N/A

FINISH SEE SUFFIX TABLE

SUPPLIER N/A

SHEET SIZE SUPP. # N/A



STANG INDUSTRIAL PRODUCTS

DIV. OF GST INDUSTRIES
16692 BURKE LN.
HUNTINGTON BEACH, CA 92647

**MONITOR, 4.0" STATION
W/BLADE BRAKE, SS**

NEW PART NUMBER	940210	
CAGE#	55822	DRAWN EK
DATE	03.01.05	DESIGN
CHECK		REVISION A
SCALE	1:8	SHEET 1 OF 1

The information and design disclosed herein is the property of GST Industries Inc. All proprietary use and sales rights thereto are reserved. This disclosure is confidential and must not be copied in whole or part.

C