

NOTES:
 1) DO NOT SCALE THIS DRAWING
 2) BREAK ALL SHARP EDGES
 3) ALL DIMENSIONS DISPLAYED IN PARENTHESES ARE FOR REFERENCE ONLY
 4) WHEN USING A DASH NUMBER WITH A DASH # SUFFIX, MAKE SURE THE DASH NUMBER SUFFIX IS THE SAME FOR THE MAJOR COMPONENTS IN THE ASSY.
 EXAMPLE: A 930160-21EP USES THE FOLLOWING MAJOR COMPONENTS:
 100707-21EP
 801212-21EP
 801228-21EP
 5) USE TEFLON TAPE ON THREADS OF THE GAUGE.

PERFORMANCE SPECIFICATIONS

WATER:
 FLOW RATE: 250-1200 USGPM
 PRESSURE RANGE: 50-150 PSIG
 PRESSURE LOSS @ 750 USGPM: 8 PSIG
 OPTIMUM PRESSURE: 120PSIG (INLET)
 MOUNTING:
 INLET: SEE CONFIGURATION TABLE
 OUTLET: 2.5" (MALE) NH THREAD
 MATERIALS:
 WATERWAY: 304SS
 SWIVELS: 304SS
 THREAD BUTT: AB
 UNIT WEIGHT: 55 LBS (DRY)

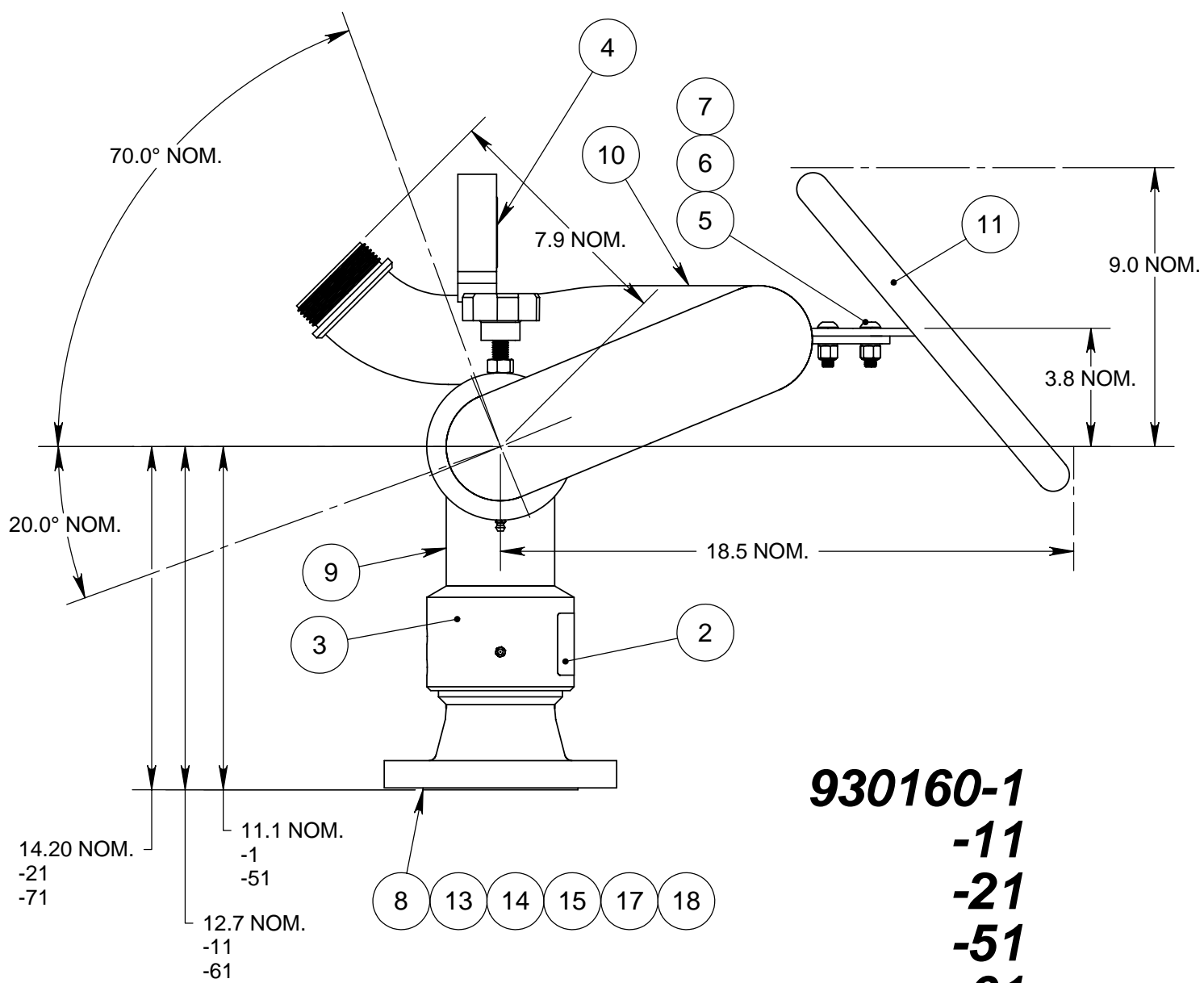
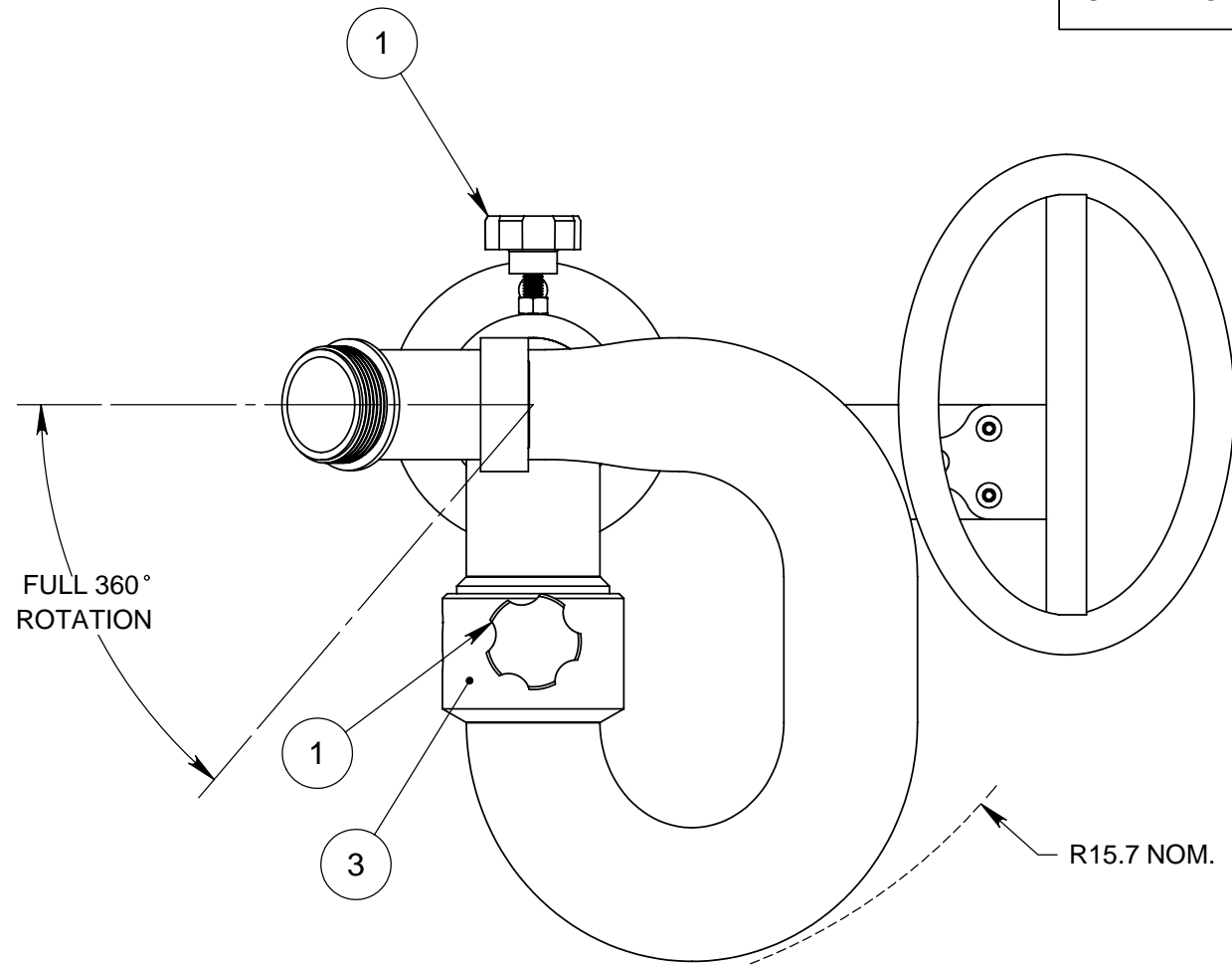

930160-1
-11
-21
-51
-61
-71

REVISIONS			
REV.	DESCRIPTION	DATE	BY
A	INITIAL RELEASE	05/11/05	EK

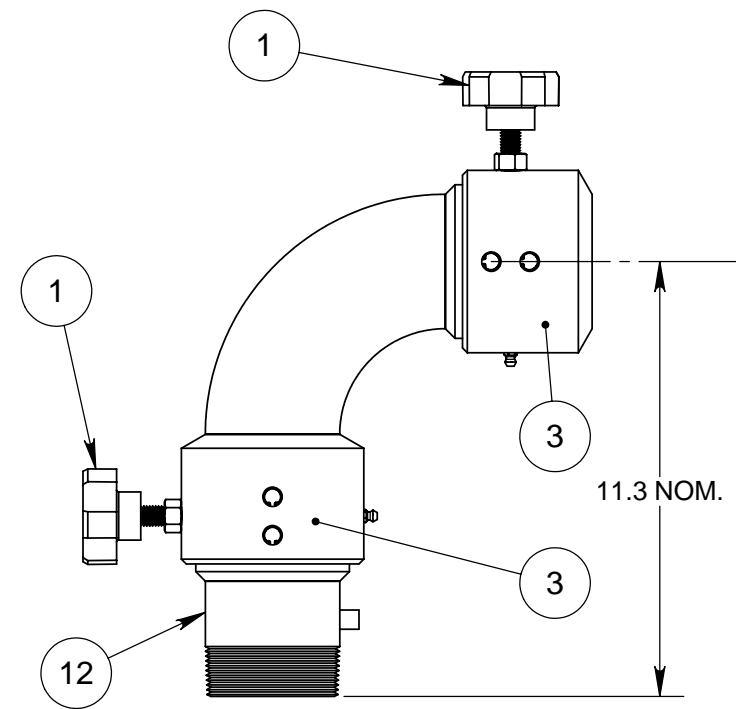

930160-31

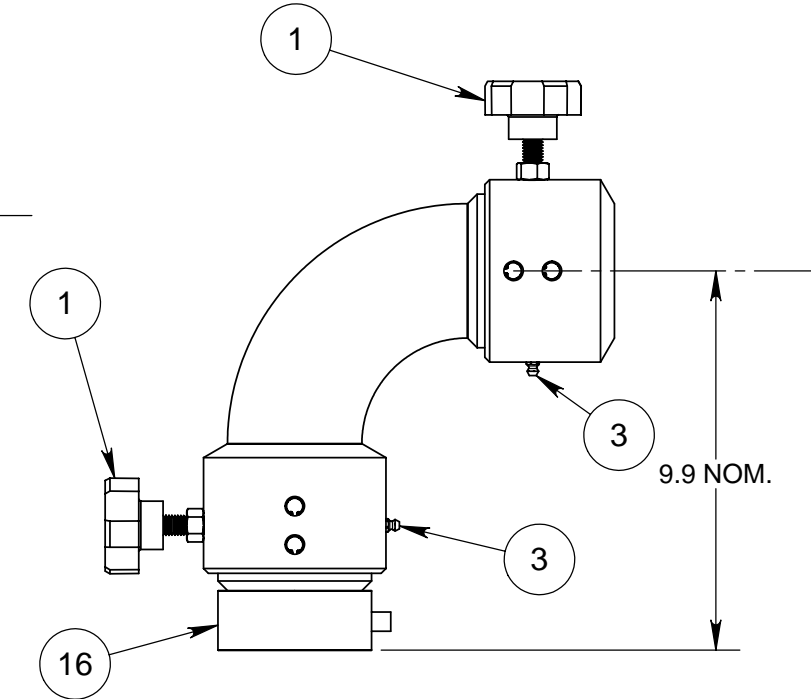

930160-41

SUFFIX TABLE	
DASH #	DESCRIPTION
NO SUFFIX	POWDER COAT STANG RED
EP	EPOXY COAT STANG RED
P	POLISHED (SS ONLY)
NP	NOT PAINTED

SEE NOTE 4

CONFIGURATION TABLE	
930160-1	MONITOR, 3.00" DECK W/3.0-150#RF, C-HANDLE & GAUGE, SS
930160-11	MONITOR, 3.00" DECK W/4.0-150#RF, C-HANDLE & GAUGE, SS
930160-21	MONITOR, 3.00" DECK W/6.0-150#RF, C-HANDLE & GAUGE, SS
930160-31	MONITOR, 3.00" DECK W/3.0NPT(M), C-HANDLE & GAUGE, SS
930160-41	MONITOR, 3.00" DECK W/3.0NPT(F), C-HANDLE & GAUGE, SS
930160-51	MONITOR, 3.00" DECK W/3.0-150#FF, C-HANDLE & GAUGE, SS
930160-61	MONITOR, 3.00" DECK W/4.0-150#FF, C-HANDLE & GAUGE, SS
930160-71	MONITOR, 3.00" DECK W/6.0-150#FF, C-HANDLE & GAUGE, SS

-	-	1	-	-	-	-	-	18	100707-51	BASE INTAKE, 3.00" W/3.0-150#FF, 304SS
-	1	-	-	-	-	-	-	17	100707-61	BASE INTAKE, 3.00" W/4.0-150#FF, 304SS
-	-	-	1	-	-	-	-	16	100707-41	BASE INTAKE, 3.00" W/3.0NPT(F), 304SS
-	-	-	-	-	1	-	-	15	100707-21	BASE INTAKE, 3.00" W/6.0-150#RF, 304SS
-	-	-	-	-	-	1	-	14	100707-11	BASE INTAKE, 3.00" W/4.0-150#RF, 304SS
1	-	-	-	-	-	-	-	13	100707-71	BASE INTAKE, 3.00" W/6.0-150#FF, 304SS
-	-	-	-	1	-	-	-	12	100707-31	BASE INTAKE, 3.00" W/3.0NPT(M), 304SS
1	1	1	1	1	1	1	1	11	100287-21	HANDLE, MONITOR REMOVABLE CIRCULAR
1	1	1	1	1	1	1	1	10	801228-21	ELL, UPPER, 3.00" DECK W/BLADELOCK & GUARD, SS
1	1	1	1	1	1	1	1	9	801212-21	ELL, LOWER, 3.00" LR, SS
-	-	-	-	-	-	-	1	8	100707-1	BASE INTAKE, 3.00" W/3.0-150#RF, 304SS
3	3	3	3	3	3	3	3	7	100249-11C	NUT, NYLOCK, 3/8-16UNC, 18-8
3	3	3	3	3	3	3	3	6	101715-38C	WASHER, FLAT, .390ID X.62OD X.063T, 18-8
3	3	3	3	3	3	3	3	5	100258-616125C	SCREW, BHC, 3/8-16UNC X 1.25L, 18-8
1	1	1	1	1	1	1	1	4	103795-6	GAUGE,PRESSURE, 300# X 2.00OD X 1/4NPT, LIQUID FILLED-SS
2	2	2	2	2	2	2	2	3	103830-1	SWIVEL KIT, 3.0 NOM.
1	1	1	1	1	1	1	1	2	100853-1	PLATE, ALUM ID
2	2	2	2	2	2	2	2	1	102537-1	LOCK KNOB, 50-20UNF-2A THD
-71/QTY.	-61/QTY.	-51/QTY.	-41/QTY.	-31/QTY.	-21/QTY.	-11/QTY.	-1/QTY.	ITEM #	PART #	DESCRIPTION

UNLESS OTHERWISE SPECIFIED: DIMENSIONS ARE IN INCHES TOLERANCES DECIMALS ANGULAR .XX ±.03 ±1° .XXX ±.010 DO NOT SCALE DRAWING

TREATMENT N/A

FINISH SEE SUFFIX TABLE

SHEET SIZE

C



STANG INDUSTRIAL PRODUCTS
 DIV. OF GST INDUSTRIES
 16692 BURKE LN.
 HUNTINGTON BEACH, CA 92647

MONITOR, 3.00" DECK
 C-HANDLE & GAUGE/GUARD-304 STAINLESS STEEL

NEW PART NUMBER	930160		
CAGE#	55822	DRAWN	EK
DATE	05/11/05	DESIGN	
CHECK		REVISION	A
SCALE	N/A	SHEET	1 OF 1

The information and design disclosed herein is the property of GST Industries Inc. All proprietary use and sales rights thereto are reserved. This disclosure is confidential and must not be copied in whole or part.