

- NOTES:  
 1) DO NOT SCALE THIS DRAWING  
 2) BREAK ALL SHARP EDGES  
 3) ALL DIMENSIONS DISPLAYED IN PARENTHESES ARE FOR REFERENCE ONLY  
 4) IF MONITOR DASH NUMBER HAS A SUFFIX SUCH AS EP MAKE SURE THAT THE MAJOR SUB-ASSEMBLIES HAVE THE SAME SUFFIX.

REVISIONS			
LTR	REVISION	DATE	BY
A	INITIAL RELEASE	01/10/06	EK

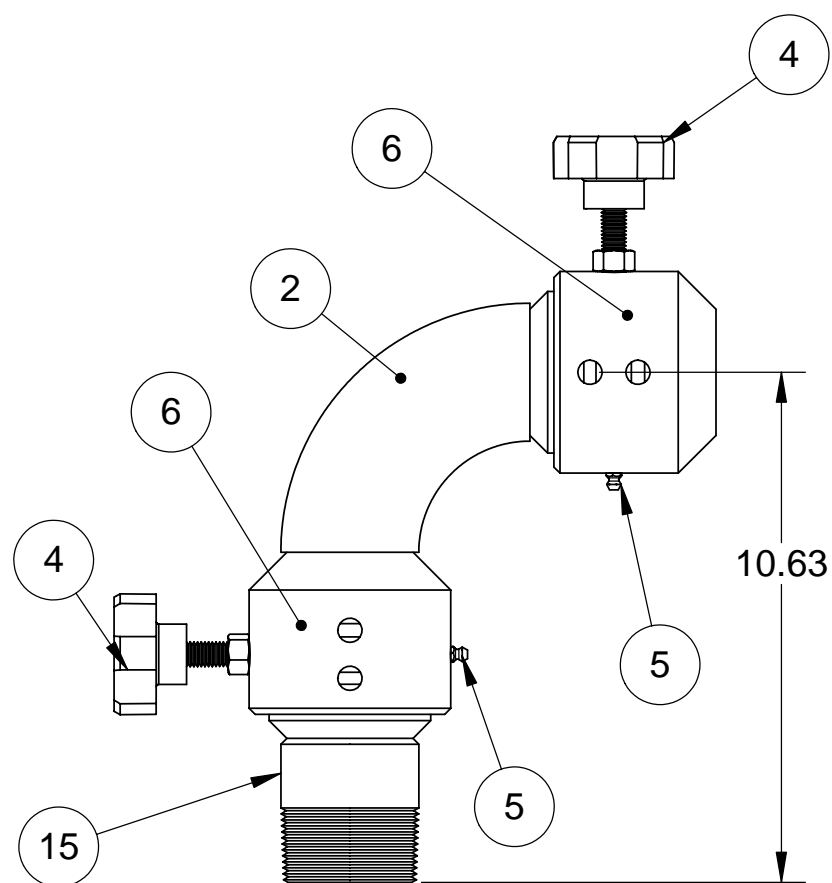

**925265-41**

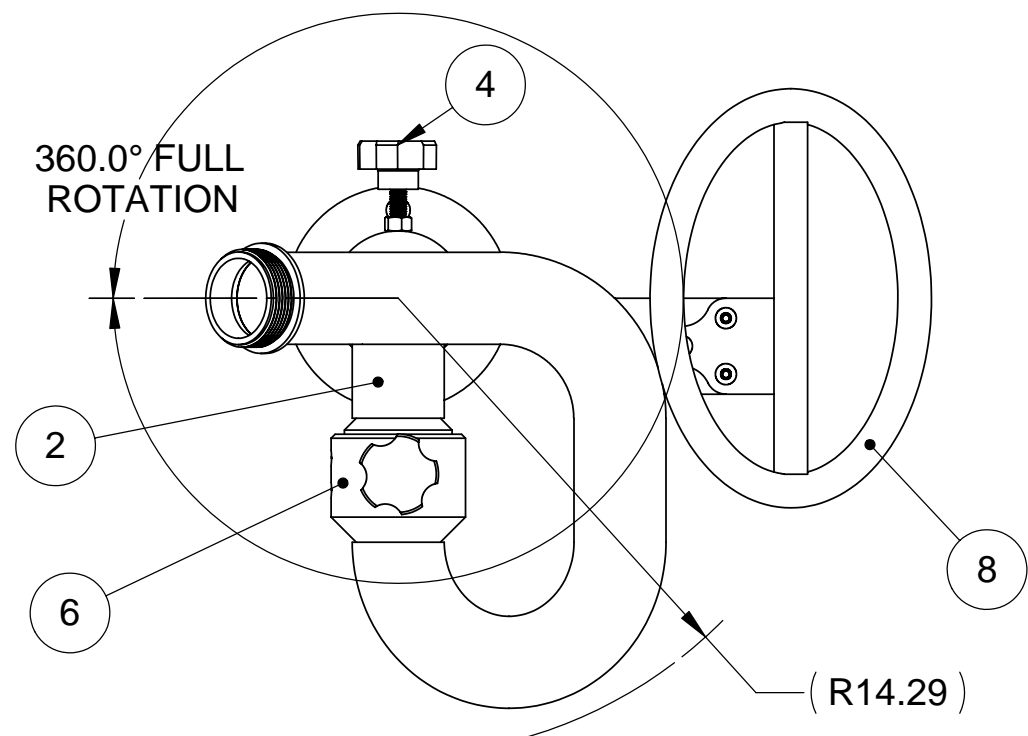
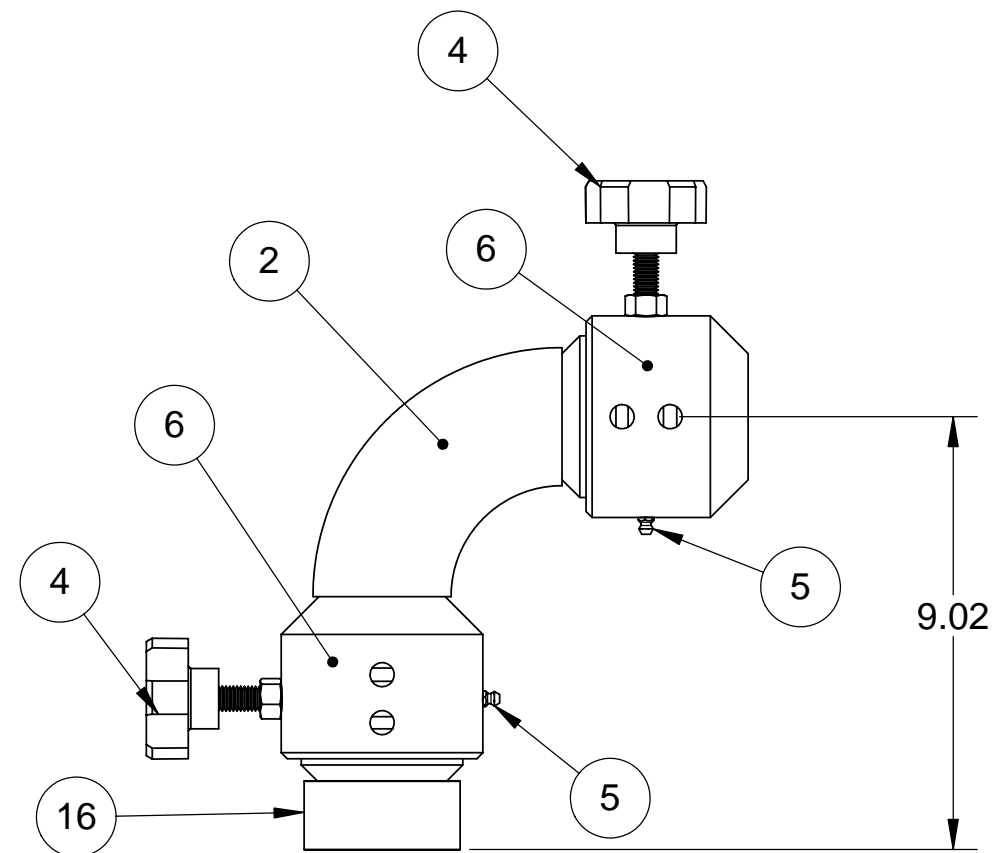

**925265-51**

CONFIGURATION TABLE	
925250-1	MONITOR, 2.50" DECK W/2.5-150#RF, C-HANDLE, SS
925250-11	MONITOR, 2.50" DECK W/3.0-150#RF, C-HANDLE, SS
925250-21	MONITOR, 2.50" DECK W/4.0-150#RF, C-HANDLE, SS
925250-31	MONITOR, 2.50" DECK W/6.0-150#RF, C-HANDLE, SS
925250-41	MONITOR, 2.50" DECK W/2.5NPT(M), C-HANDLE, SS
925250-51	MONITOR, 2.50" DECK W/2.5NPT(F), C-HANDLE, SS
925250-61	MONITOR, 2.50" DECK W/2.5-150#FF, C-HANDLE, SS
925250-71	MONITOR, 2.50" DECK W/3.0-150#FF, C-HANDLE, SS
925250-81	MONITOR, 2.50" DECK W/4.0-150#FF, C-HANDLE, SS
925250-91	MONITOR, 2.50" DECK W/6.0-150#FF, C-HANDLE, SS

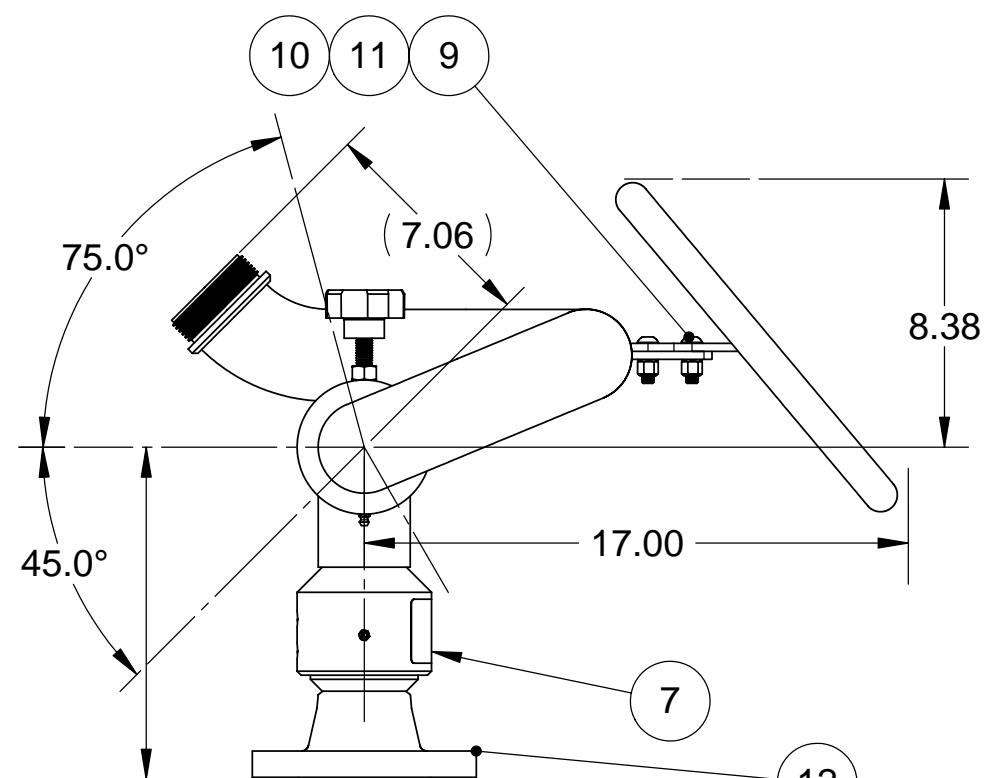

- (10.38) P/N: 925265-1, -61
- (11.51) P/N: 925265-11, -71
- (12.00) P/N: 925265-21, -81
- (13.51) P/N: 925265-31, -91

**925265**

- 1**
- 11**
- 21**
- 31**
- 61**
- 71**
- 81**
- 91**

- 1
- 13
- 14
- 17
- 18
- 19
- 20

SUFFIX TABLE	
DASH #	DESCRIPTION
NO SUFFIX	POWDER COAT STANG RED
EP	EPOXY COAT STANG RED
P	POLISHED (SS ONLY)
NP	NOT PAINTED

SEE NOTE 4

1	-	-	-	-	-	-	-	-	-	20	802095-71	BASE INTAKE, 2.50" W/6.0-150#FF FLG, SS-AB
-	1	-	-	-	-	-	-	-	-	19	802095-61	BASE INTAKE, 2.50" W/4.0-150#FF FLG, SS-AB
-	-	1	-	-	-	-	-	-	-	18	802095-51	BASE INTAKE, 2.50" W/3.0-150#FF FLG, SS-AB
-	-	-	1	-	-	-	-	-	-	17	802095-41	BASE INTAKE, 2.50" W/2.5-150#FF FLG, SS-AB
-	-	-	-	1	-	-	-	-	-	16	802095-91	BASE INTAKE, 2.50" W/2.5NPT(F), SS-AB
-	-	-	-	-	1	-	-	-	-	15	802095-81	BASE INTAKE, 2.50" W/2.5NPT(M), SS-AB
-	-	-	-	-	-	1	-	-	-	14	802095-31	BASE INTAKE, 2.50" W/6.0-150#RF FLG, SS-AB
-	-	-	-	-	-	-	1	-	-	13	802095-21	BASE INTAKE, 2.50" W/4.0-150#RF FLG, SS-AB
-	-	-	-	-	-	-	-	-	1	12	802095-1	BASE INTAKE, 2.50" W/2.5-150#RF FLG, SS-AB
3	3	3	3	3	3	3	3	3	3	11	100249-11C	NUT, NYLOCK, 3/8-16UNC, 18-8
3	3	3	3	3	3	3	3	3	3	10	101715-38C	WASHER, FLAT, .390ID X.62OD X.063T, 18-8
3	3	3	3	3	3	3	3	3	3	9	100258-616125C	SCREW, BHC, 3/8-16UNC X 1.25L, 18-8
1	1	1	1	1	1	1	1	1	1	8	100287-21	HANDLE, MONITOR REMOVABLE CIRCULAR
1	1	1	1	1	1	1	1	1	1	7	100853-1	PLATE, ALUM ID
2	2	2	2	2	2	2	2	2	2	6	103829-1	SWIVEL KIT, 2.5 NOM.
2	2	2	2	2	2	2	2	2	2	5	100112-8	FITTING, ZERK, STR, 1/4-28UNF, CRES
2	2	2	2	2	2	2	2	2	2	4	102537-1	LOCK KNOB, 50-20UNF-2A THD
1	1	1	1	1	1	1	1	1	1	3	801203-21	ELL, UPPER, 2.50" DECK, SS
1	1	1	1	1	1	1	1	1	1	2	801208-21	ELL, LOWER, 2.50" LR, SS
-	-	-	-	-	-	-	-	-	1	1	802095-11	BASE INTAKE, 2.50" W/3.0-150#RF FLG, SS-AB
-91/QTY.	-81/QTY.	-71/QTY.	-61/QTY.	-51/QTY.	-41/QTY.	-31/QTY.	-21/QTY.	-11/QTY.	-1/QTY.	ITEM NO.	PART NO	DESCRIPTION

UNLESS OTHERWISE SPECIFIED: DIMENSIONS ARE IN INCHES TOLERANCES DECIMALS ANGULAR .XX ±.03 ±1° .XXX ±.010 DO NOT SCALE DRAWING

TREATMENT N/A

FINISH SEE SUFFIX TABLE

SIZE SUPP. #

**STANG INDUSTRIAL PRODUCTS**

1250 RAILROAD ST.  
CORONA, CA 92882

**MONITOR, 2.50" DECK, C-HANDLE, SS**

NEW PART NUMBER **925265** SS

CAGE# 55822 DRAWN EK CHECK REVISION A

DATE 01/10/06 DESIGN SCALE NTS SHEET 1 OF 1

The information and design disclosed herein is the property of GST Industries Inc. All proprietary use and sales rights thereto are reserved. This disclosure is confidential and must not be copied in whole or part.