

NOTES:
 1) DO NOT SCALE THIS DRAWING
 2) BREAK ALL SHARP EDGES
 3) ALL DIMENSIONS DISPLAYED IN PARENTHESES ARE FOR REFERENCE ONLY.
 4) IF MONITOR DASH NUMBER HAS A SUFFIX SUCH AS EP MAKE SURE THAT THE MAJOR SUB-ASSEMBLIES HAVE THE SAME SUFFIX.

REVISIONS			
LTR	REVISION	DATE	BY
A	INITIAL RELEASE	06/26/06	EK

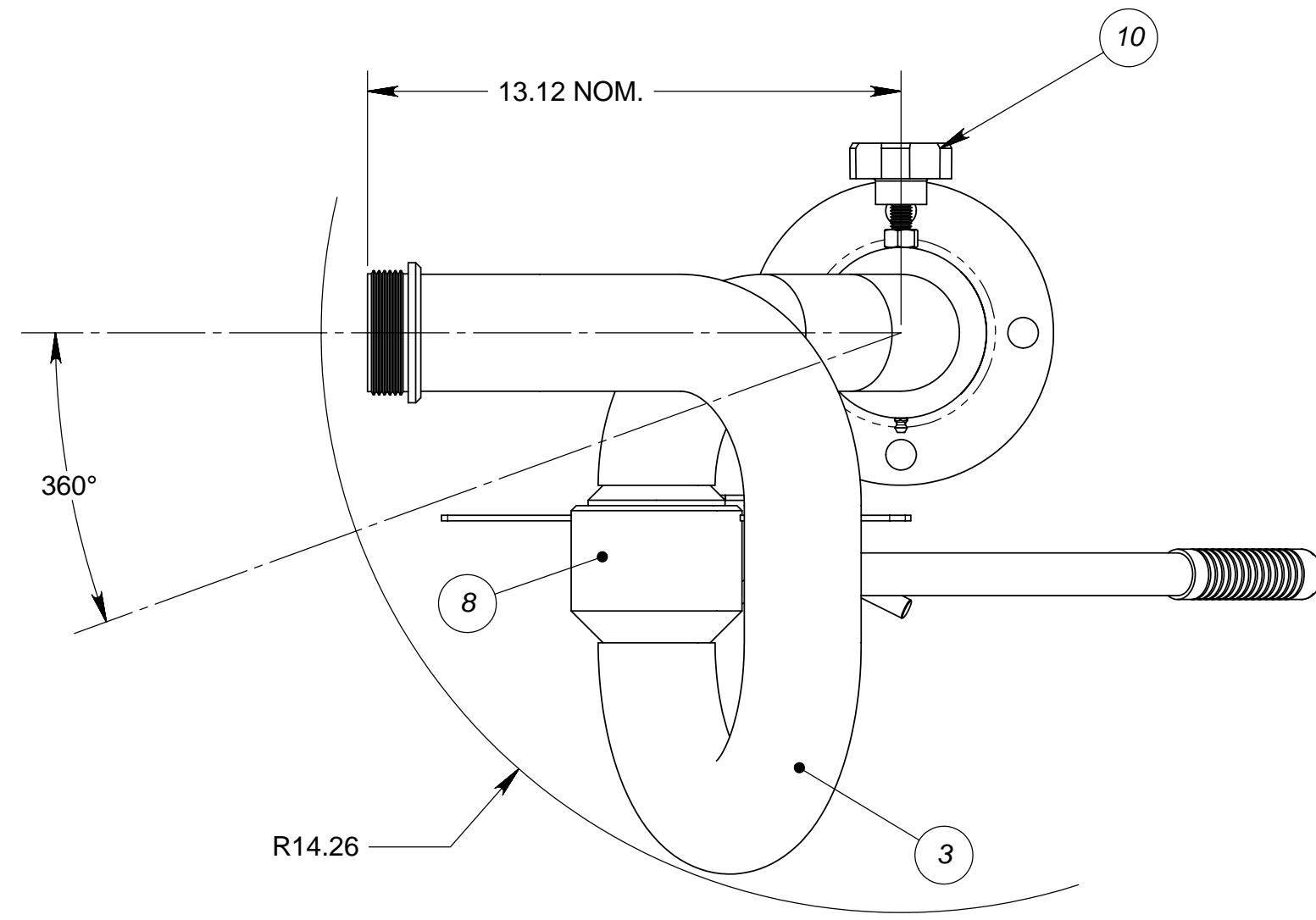

925010-41

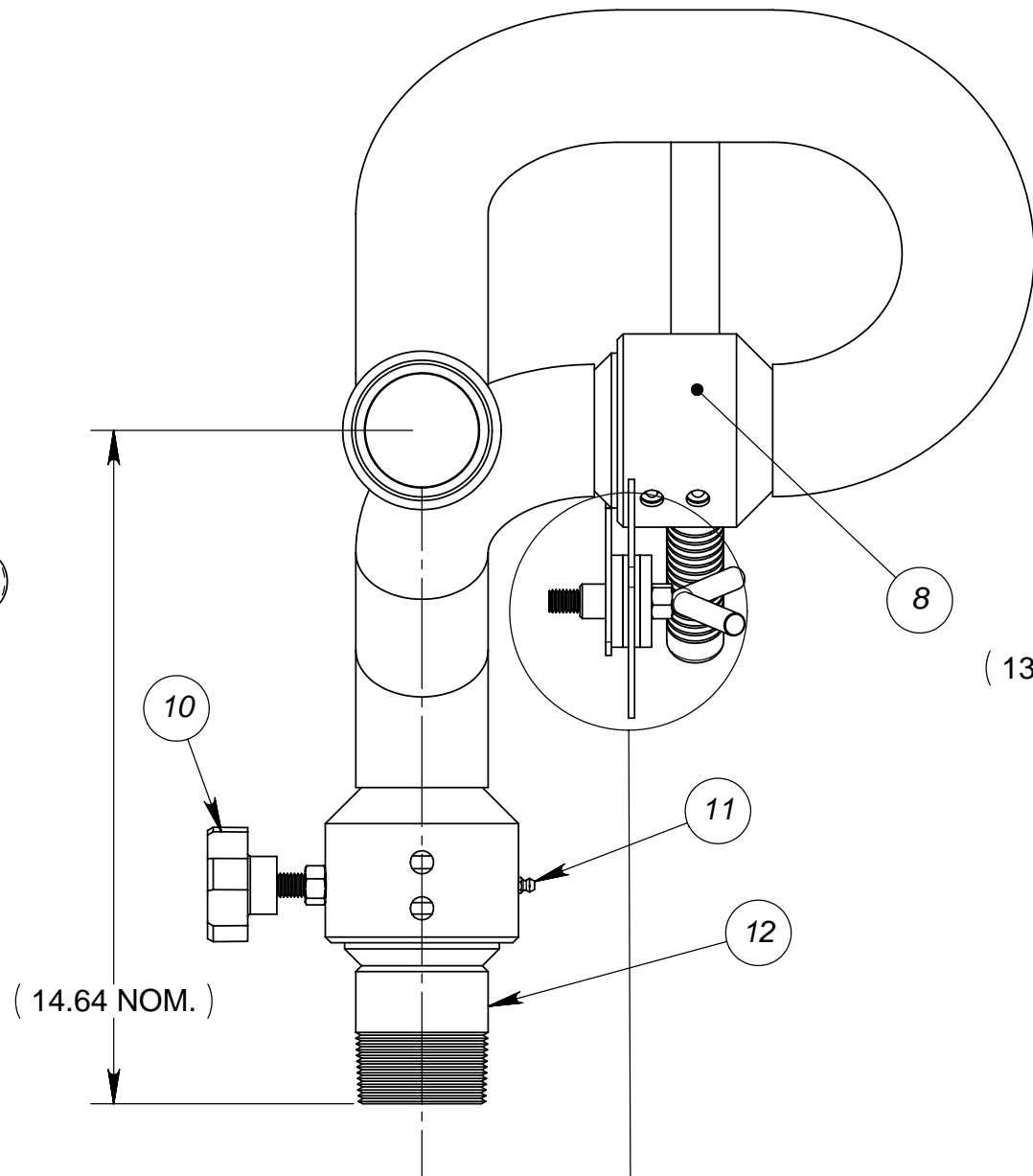

925010-51

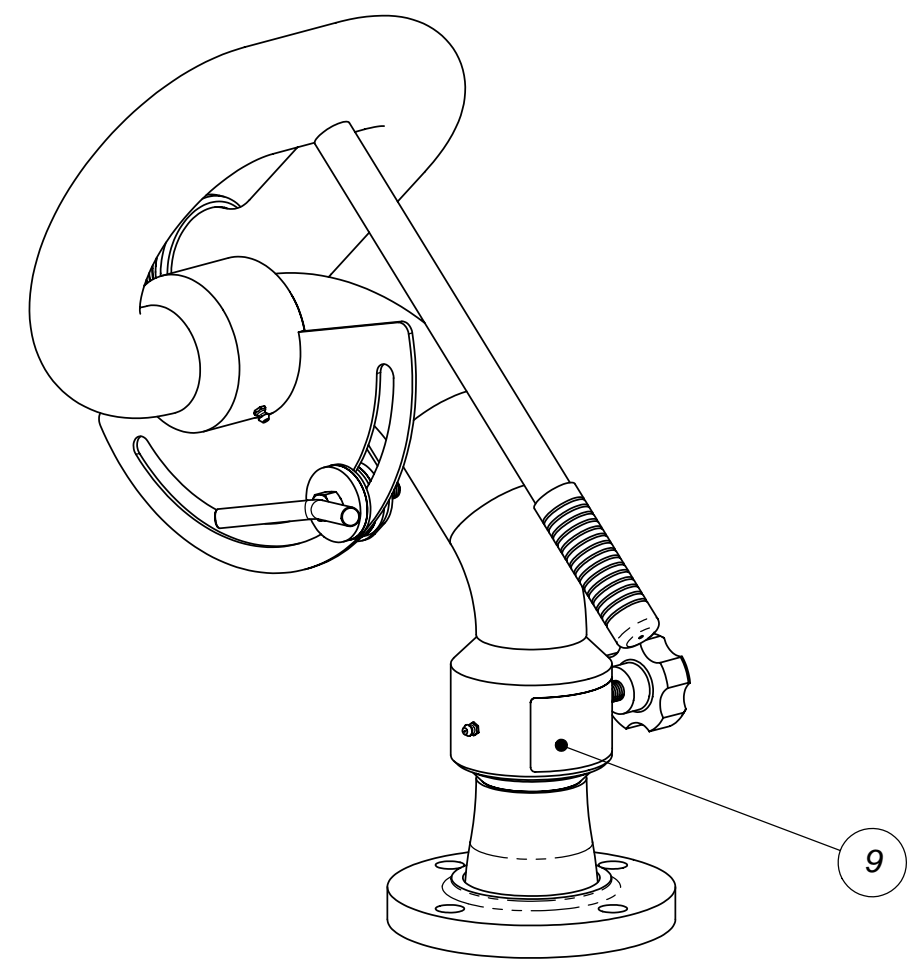
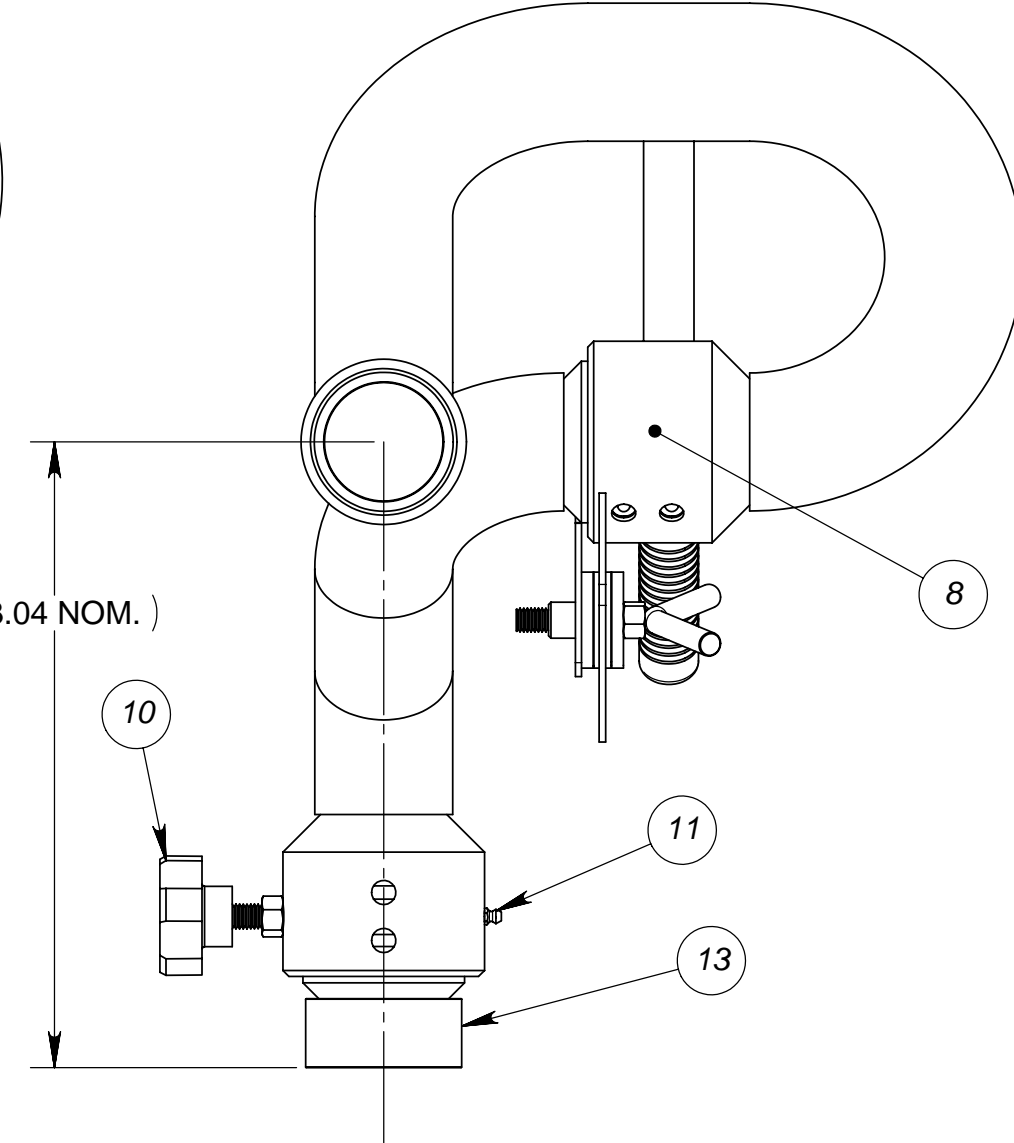

GENERAL SPECS

- WATER:
 - FLOW RATE: 250-1000 USGPM
 - OPER. PRESSURE RANGE: 50-150 PSI
 - PRESSURE LOSS @ 750 USGPM: 16 PSI
 - OPTIMUM OPER. PRESSURE: 120PSI (INLET)
- TRAVEL
 - VERTICAL +75° -90°
 - HORIZONTAL 360°
- MOUNTING:
 - INLET: SEE CONFIGURATION CHART
 - OUTLET: 2.5" (MALE) NH THREAD
- MATERIALS:
 - WATERWAY: STAINLESS STEEL (COATED INSIDE AND OUT)
 - SWIVELS: ALUMINUM NICKEL BRONZE
 - THREAD BUTT: ALUMINUM NICKEL BRONZE

UNIT WEIGHT: VARIOUS/ APPROX 50LBS (DRY)

SUFFIX TABLE (SEE NOTES)

DASH NUMBER SUFFIX	RED FINISH
NO SUFFIX	RED FINISH
EP	RED EPOXY FINISH
P	POLISH (SS) ONLY
NP	NO PAINT

CONFIGURATIONS

925010-1	MONITOR, 2.50" SNORKEL W/2.5-150#RF & BL, SS-AB
925010-11	MONITOR, 2.50" SNORKEL W/3.0-150#RF & BL, SS-AB
925010-21	MONITOR, 2.50" SNORKEL W/4.0-150#RF & BL, SS-AB
925010-31	MONITOR, 2.50" SNORKEL W/6.0-150#RF & BL, SS-AB
925010-41	MONITOR, 2.50" SNORKEL W/2.5NPT(M) & BL, SS-AB
925010-51	MONITOR, 2.50" SNORKEL W/2.5NPT(F) & BL, SS-AB
925010-61	MONITOR, 2.50" SNORKEL W/2.5-150#FF & BL, SS-AB
925010-71	MONITOR, 2.50" SNORKEL W/3.0-150#FF & BL, SS-AB
925010-81	MONITOR, 2.50" SNORKEL W/4.0-150#FF & BL, SS-AB
925010-91	MONITOR, 2.50" SNORKEL W/6.0-150#FF & BL, SS-AB

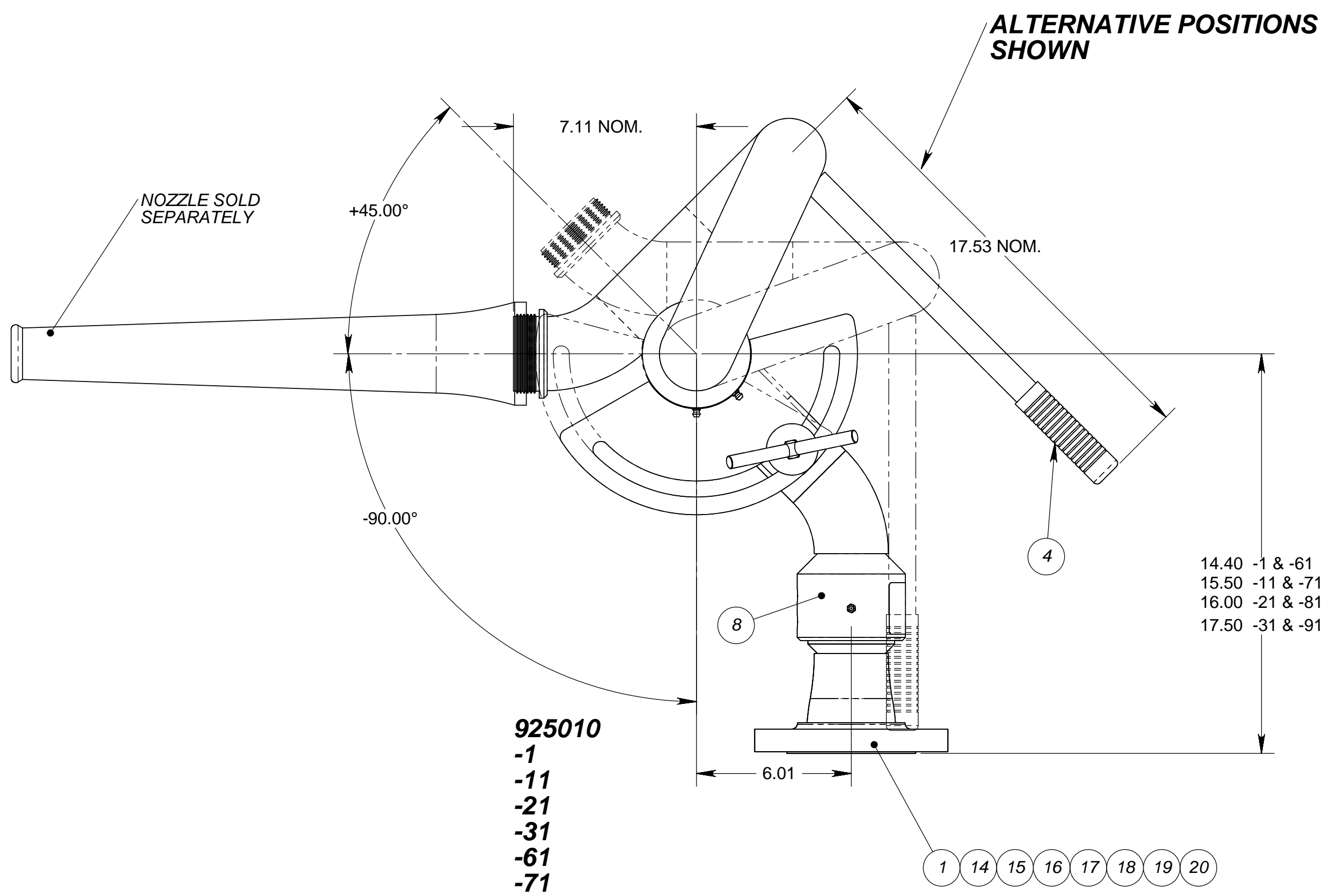

925010
 -1
 -11
 -21
 -31
 -61
 -71
 -81
 -91

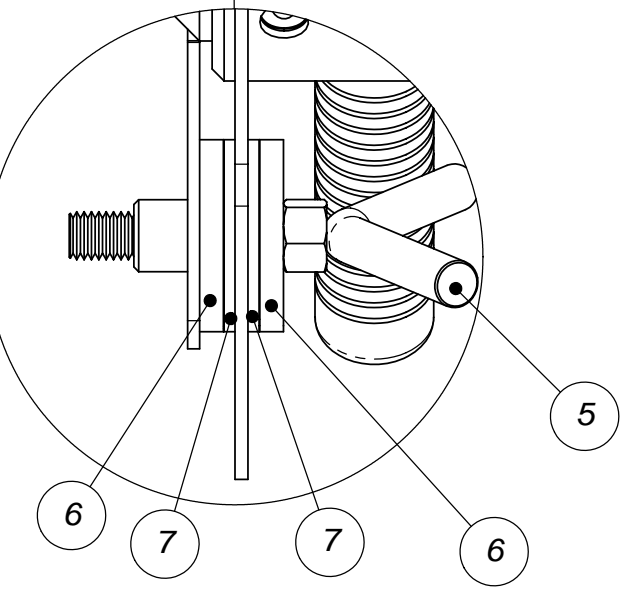

-	-	-	-	-	-	-	-	-	-	1	20	802090-1	BASE INTAKE, 2.50" W/2.5-150#RF FLG, SS-AB
-	-	-	-	-	-	-	-	1	-	-	19	802090-21	BASE INTAKE, 2.50" W/4.0-150#RF FLG, SS-AB
-	-	-	-	-	-	-	-	-	-	1	18	802090-31	BASE INTAKE, 2.50" W/6.0-150#RF FLG, SS-AB
1	-	-	-	-	-	-	-	-	-	-	17	802090-71	BASE INTAKE, 2.50" W/6.0-150#FF FLG, SS-AB
-	1	-	-	-	-	-	-	-	-	-	16	802090-61	BASE INTAKE, 2.50" W/4.0-150#FF FLG, SS-AB
-	-	1	-	-	-	-	-	-	-	-	15	802090-51	BASE INTAKE, 2.50" W/3.0-150#FF FLG, SS-AB
-	-	-	1	-	-	-	-	-	-	-	14	802090-41	BASE INTAKE, 2.50" W/2.5-150#FF FLG, SS-AB
-	-	-	-	1	-	-	-	-	-	-	13	802090-91	BASE INTAKE, 2.50" W/2.5NPT(F), SS-AB
-	-	-	-	-	1	-	-	-	-	-	12	802090-81	BASE INTAKE, 2.50" W/2.5NPT(M), SS-AB
2	2	2	2	2	2	2	2	2	2	2	11	100112-8	FITTING, ZERK, STR, 1/4-28UNF, CRES
1	1	1	1	1	1	1	1	1	1	1	10	102537-1	LOCK KNOB, 50-20UNF-2A THD
1	1	1	1	1	1	1	1	1	1	1	9	100853-1	PLATE, ALUM ID
2	2	2	2	2	2	2	2	2	2	2	8	103829-1	SWIVEL KIT, 2.5 NOM.
2	2	2	2	2	2	2	2	2	2	2	7	105448-11	WASHER, FLAT, .50ID X 2.00OD X.120T, DELRIN
2	2	2	2	2	2	2	2	2	2	2	6	103817-11	WASHER, FLAT, .200OD X .56ID X .25T, 304
1	1	1	1	1	1	1	1	1	1	1	5	103815-11	LOCK HANDLE WELDMENT
1	1	1	1	1	1	1	1	1	1	1	4	100256-2	GRIP,HAND,BLK PLSTC.#RG14055
1	1	1	1	1	1	1	1	1	1	1	3	801175-41-90	ELL, UPPER, 2.50" SNORKEL, BL W/HANDLE@90°, SS-AB
1	1	1	1	1	1	1	1	1	1	1	2	801288-41	ELL, LOWER, 2.50" SNORKEL W/BL, STL
-	-	-	-	-	-	-	-	-	-	1	1	802090-11	BASE INTAKE, 2.50" W/3.0-150#RF FLG, SS-AB
-91/QTY.	-81/QTY.	-71/QTY.	-61/QTY.	-51/QTY.	-41/QTY.	-31/QTY.	-21/QTY.	-11/QTY.	-1/QTY.	ITEM NO.	PART #	DESCRIPTION	

UNLESS OTHERWISE SPECIFIED: DIMENSIONS ARE IN INCHES
 TOLERANCES
 DECIMALS ANGULAR
 .XX ±.03 ±2°
 .XXX ±.010

DO NOT SCALE DRAWING

TREATMENT N/A

FINISH SEE SUFFIX TABLE

SIZE SUPP.#

D N/A

STANG INDUSTRIAL PRODUCTS
 1250 RAILROAD ST.
 CORONA, CA 92882

MONITOR, 2.50" SNORKEL W/BLADELOCK

PIN 925010 MATL SS-AB

CAGE# 55822 DRAWN EK CHECK

DATE 06/26/06 DESIGN SCALE NTS SHEET 1 OF 1

The information and design disclosed herein is the property of Stang Industries Inc. All proprietary use and sales rights thereto are reserved. This disclosure is confidential and must not be copied in whole or part.