

**NOTES:**

1. DO NOT SCALE THIS DRAWING.
2. BREAK ALL SHARP EDGES.
3. ALL DIMENSIONS DISPLAYED IN PARENTHESES ARE FOR REFERENCE ONLY.
4. IF DASH NUMBER HAS A SUFFIX, MAKE SURE ALL MAJOR PART NUMBERS HAVE THE SAME SUFFIX. BASE INTAKE, LOWER ELL, & UPPER ELL

REVISIONS			
REV.	DESCRIPTION	DATE	BY
A	INITIAL RELEASE	09/06/06	EK

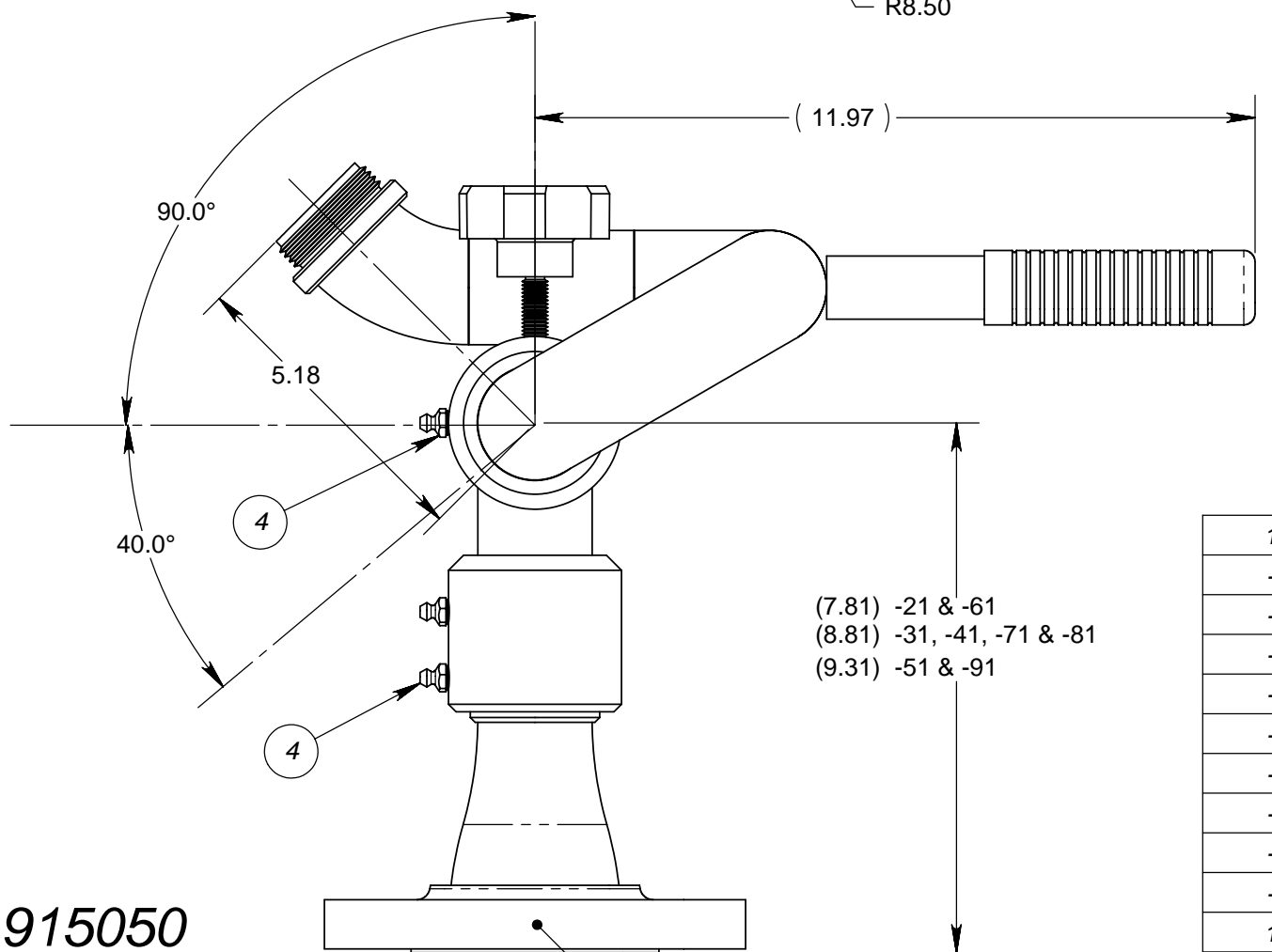
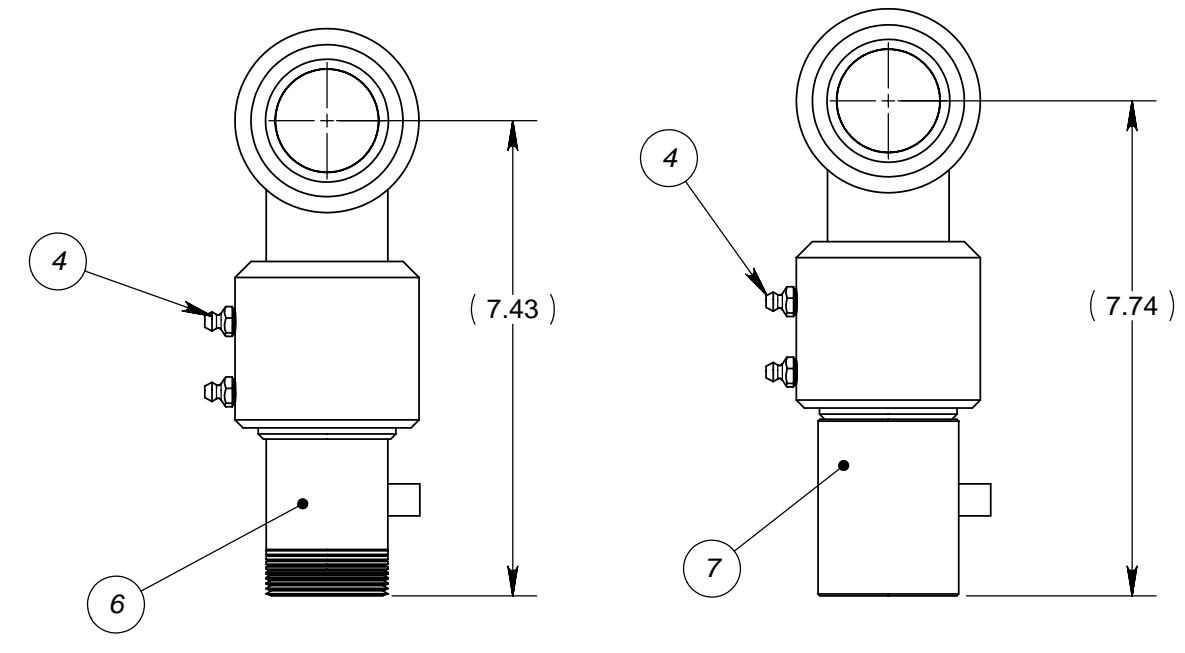
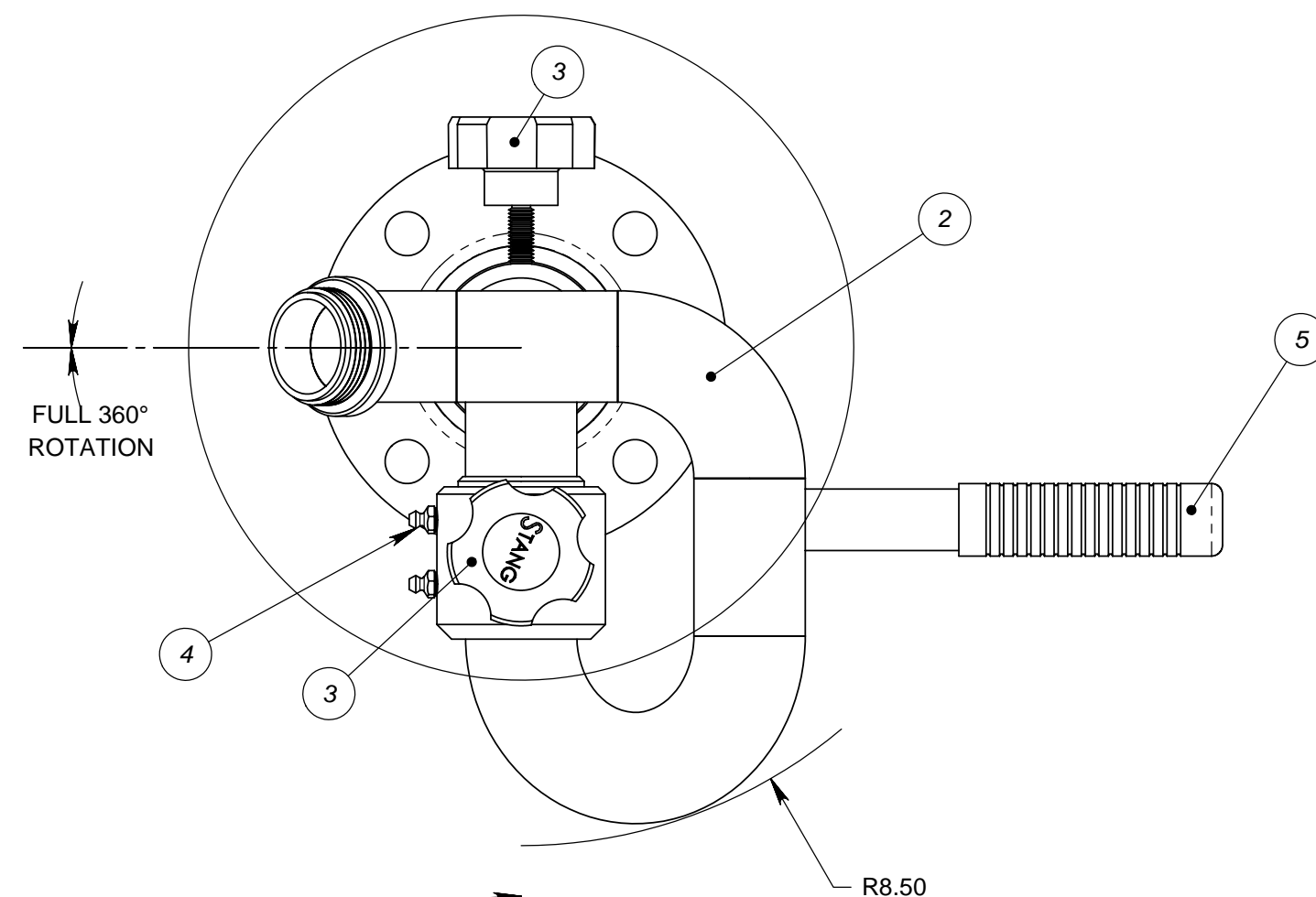

**915050**  
**-21**  
**-31**  
**-41**  
**-51**  
**-61**  
**-71**  
**-81**  
**-91**



9  
8  
10  
11  
12  
13  
14  
15

DASH NUMBER SUFFIX KEY	
NO SUFFIX	POWDER COAT STANG RED
EP	EPOXY COAT STANG RED
P	POLISH (SS ONLY)
NP	NO PAINT
FOR ALL OTHER VARIATIONS USE VCN	

CONFIGURATION KEY	
-1	MONITOR, 1.50" STATION W/1.5NPT(M), STL-AB
-11	MONITOR, 1.50" STATION W/1.5NPT(F), STL-AB
-21	MONITOR, 1.50" STATION W/1.50-150#RF, STL-AB
-31	MONITOR, 1.50" STATION W/2.50-150#RF, STL-AB
-41	MONITOR, 1.50" STATION W/3.00-150#RF, STL-AB
-51	MONITOR, 1.50" STATION W/4.00-150#RF, STL-AB
-61	MONITOR, 1.50" STATION W/1.50-150#FF, STL-AB
-71	MONITOR, 1.50" STATION W/2.50-150#FF, STL-AB
-81	MONITOR, 1.50" STATION W/3.00-150#FF, STL-AB
-91	MONITOR, 1.50" STATION W/4.00-150#FF, STL-AB

1	-	-	-	-	-	-	-	-	-	15	802039-71	BASE INTAKE, 1.50" W/4.0-150#FF FLG, STL-AB
-	1	-	-	-	-	-	-	-	-	14	802039-61	BASE INTAKE, 1.50" W/3.0-150#FF FLG, STL-AB
-	-	1	-	-	-	-	-	-	-	13	802039-51	BASE INTAKE, 1.50" W/2.5-150#FF FLG, STL-AB
-	-	-	1	-	-	-	-	-	-	12	802039-41	BASE INTAKE, 1.50" W/1.5-150#FF FLG, STL-AB
-	-	-	-	1	-	-	-	-	-	11	802039-31	BASE INTAKE, 1.50" W/4.0-150#RF FLG, STL-AB
-	-	-	-	-	1	-	-	-	-	10	802039-21	BASE INTAKE, 1.50" W/3.0-150#RF FLG, STL-AB
-	-	-	-	-	-	1	-	-	-	9	802039-11	BASE INTAKE, 1.50" W/2.5-150#RF FLG, STL-AB
-	-	-	-	-	-	-	1	-	-	8	802039-1	BASE INTAKE, 1.50" W/1.5-150#RF FLG, STL-AB
-	-	-	-	-	-	-	-	1	-	7	802043-91	BASE INTAKE, 1.50" W/1.5NPT(F), SS-AB
-	-	-	-	-	-	-	-	-	1	6	802043-81	BASE INTAKE, 1.50" W/1.5NPT(M), SS-AB
1	1	1	1	1	1	1	1	1	1	5	100256-2	GRIP,HAND,BLK PLSTC.#RG14055
2	2	2	2	2	2	2	2	2	2	4	103828-1	SWIVEL KIT, 1.5 NOM.
2	2	2	2	2	2	2	2	2	2	3	101128-3	KNOB, 3/8-16UNC, BLACK PHENOLIC
1	1	1	1	1	1	1	1	1	1	2	801301-11	ELL, UPPER, 1.50" STATION, STL-AB
1	1	1	1	1	1	1	1	1	1	1	801292-11	ELL, LOWER, 1.50" LR, STL-AB
-91/QTY.	-81/QTY.	-71/QTY.	-61/QTY.	-51/QTY.	-41/QTY.	-31/QTY.	-21/QTY.	-11/QTY.	-1/QTY.	ITEM NO.	PART #	DESCRIPTION

The information and design disclosed herein is the property of Stang Industries Inc. All proprietary use and sales rights thereto are reserved. This disclosure is confidential and must not be copied in whole or part.

UNLESS OTHERWISE SPECIFIED: DIMENSIONS ARE IN INCHES TOLERANCES DECIMALS ANGULAR .XX ±.03 ±1° .XXX ±.010 DO NOT SCALE DRAWING		 <b>STANG INDUSTRIES INC.</b> 1250 RAILROAD ST. CORONA, CA 92882							
TREATMENT	N/A								
FINISH	SEE SUFFIX KEY	<b>MONITOR, 1.50" STATION</b>							
SUPPLIER	N/A								
SHEET SIZE	SUPP. #	NEW PART NUMBER	<b>915050</b>	STL-AB					
		CAGE#	55822	DRAWN	EK	CHECK		REVISION	A
		DATE	09/06/06	DESIGN		SCALE	1:4	SHEET	1 OF 1